

Transient Behaviour of Three Phase Induction Motor Under Supply Interruption of One Phase During Starting

Biswarup Basak

Abstract—Transient performance of three phase induction motor plays a vital role in power system. This is more severe when one phase is interrupted due to chattering of contactors during starting. Transient behaviour of motor under such condition has been examined using SIMULINK model and explained with respect of air gap field behaviour.

Index Terms—Induction motor transients, Induction motor starting, Starting transients, Transient analysis

I. INTRODUCTION

QUALITY of power supply depends not only on the generation and transmission or distribution network but also highly influenced by the nature of loads. Therefore in power system stability and contingency analysis the effect of load should be taken with due considerations. In most of the cases for such analysis, it is assumed that the load is linear. But modern equipment, mainly where power electronics components are used, do not behave as linear load rather they are of highly non-linear characteristics. When such equipment are connected to even a healthy sinusoidal supply, input current pattern is widely away from sinusoid. And such non-sinusoidal currents are to be supplied by the system. The case is more severe when such loads are operated from single phase supply and proper phase balancing is not done. Such load generated harmonic current not only causes additional heat loss in the system, it also causes unbalance system current resulting in positive, negative and in some cases zero sequence components. Because of these reasons, in some distribution network it has been surprisingly, observed that the neutral current is more than the phase currents.

During the conventional analysis of power system behaviour with conventional passive loads e.g. resistance, inductance, capacitance or active loads e.g. motors, generators etc. usually their non-linearities are neglected. This concept may partly be accepted under steady state healthy operating condition. But in reality magnetic circuit of motors is highly non-linear specially under varying operating voltage condition and also under starting transients. Hence, transient behaviour of electrical motors has major role to play in the

system stability as well as power quality. But not much attention has been paid towards this.

Induction motors because of their wide applications continue to stay at the focus of research even today. While there are information galore on the steady state performances of these motors, a more is yet to come out on their transient performances under different operating conditions. So any exercise aimed at understanding the motor behaviour in depth is useful and rewarding. With the use of advanced software packages available now-a-days, the computers have added a new dimension in the field of computation and machine analysis. In this work an attempt is made to study the transient performance of the motor during starting with different operating conditions. The behaviour of motor current, torque, speed and air gap field are examined and the results are interpreted with an alternative approach using the concept of modulation.

Some amount of work has already been reported [1] on the transient performance of three phase induction motor due to sudden change of load or sudden change of supply voltage. In this paper attention has been given to study the motor starting performance if any one phase is interrupted during starting process. This is a common phenomenon in case of chattering of contactor at the time of closing. One interruption during the starting period has been taken as case study for driving three different types of loads: no load, constant torque load and fan type load.

II. SIMULATION MODEL

The variation of motor current, torque and speed during start up under different operating conditions are simulated using SIMULINK model under MATLAB. The model has been developed using equations in stationary d-q reference frame for positive sequence as well as negative sequence components. Since in most of the cases the motors are connected to three phase three wire system the zero sequence component in the supply voltage has been ignored. Effects of all the sequence components have been taken together for obtaining the final result for torque and speed. The motor phase winding currents have also been monitored from which the line current can easily be computed. In this developed model due consideration has been taken for incorporation of magnetic non-linearities as a function of magnetizing current by using look up tables. The forms of the equations used for simulation model is shown below. Proper considerations for sequence components have been implemented.

B. Basak is with the Department of Electrical Engineering, Bengal Engineering College (Deemed University), Howrah 711103, W.B. INDIA (telephone: 91-33-6684561, e-mail: biswarup_basak@hotmail.com)

The voltage and current equations :

$$v_{ds} = r_s i_{ds} + (l_s + L_m) p i_{ds} + L_m p i_{dr} \quad (1)$$

$$v_{qs} = r_s i_{qs} + (l_s + L_m) p i_{qs} + L_m p i_{qr} \quad (2)$$

$$v_{dr} = 0 = r_r i_{dr} + (l_r + L_m) p i_{dr} + L_m p i_{ds} + \omega_r [(l_s + L_m) i_{qr} + L_m i_{qs}] \quad (3)$$

$$v_{qr} = 0 = r_r i_{qr} + (l_r + L_m) p i_{qr} + L_m p i_{qs} + \omega_r [(l_s + L_m) i_{dr} + L_m i_{ds}] \quad (4)$$

Electromagnetic torque equation :

$$T_e = -\frac{3P}{2} \frac{L_m}{2} (i_{ds} i_{qr} - i_{qs} i_{dr}) \quad (5)$$

Rotor speed equation :

$$\omega_r = \int \frac{P}{2J} (T_e - T_L) dt \quad (6)$$

Air gap field speed equation :

$$P\alpha = \frac{\cos \alpha \frac{di_q}{dt} - \sin \alpha \frac{di_d}{dt}}{\sqrt{(i_{ds} + i_{dr})^2 + (i_{qs} + i_{qr})^2}} \quad (7)$$

where,

L_m = magnetizing inductance per phase

l = leakage inductance per phase

r = resistance per phase

v = applied voltage per phase

i = current per phase

ω_r = rotor speed

s = subscript indicates stator quantities

r = subscript indicates rotor quantities referred to stator

d = subscript referred to direct axis

q = subscript referred to quadrature axis

P = number of poles

p = d/dt

α = instantaneous space angle between d-axis and air gap field

J = total inertia of the system ($J_m + J_L$)

T_L = shaft torque

III. RESULTS AND DISCUSSIONS

The motor under study is of rating 3 phase, 5 hp, 220 volts, 4 pole squirrel cage induction motor having per phase parameters: stator resistance, $r_s = 1.16$ ohms, rotor resistance, $r_r = 3.515$ ohms, stator leakage inductance, $l_s = 0.024$ H, rotor leakage inductance, $l_r = 0.0034$ H, magnetizing inductance, $L_m = 0.312$ H, rotor inertia, $J_m = 0.024$ kgm^2 , load inertia, $J_L = 0.024$ kgm^2 .

The variation of motor current, torque, rotor speed and air gap field speed during start up are computed using Runge-Kutta order 5 algorithm under SIMULINK toolbox of MATLAB. Also air gap field locus showing how it builds up from zero to its steady state value is observed. All these

quantities are examined under different loading conditions when supply of one phase (phase c) is interrupted from 50 msec to 75 msec after the initiation of starting. The effect of interruption of supply and the nature of load are examined. Fig 1, 2 and 3 depict starting performance under no load, constant load and fan type load conditions respectively.

Initial oscillations with a few going negative during the early part of the motor start-up are observed in the torque pattern of all the above cases (Fig. 1(a), 2(a), 3(a)). From Fig. 1(b), 2(b), and 3(b) it is also noted that the rise in rotor speed is not smooth and is accompanied with speed drops during the initial period of acceleration. Interestingly a seemingly impossible situation is observed on no load when the induction motor runs above synchronous speed for some time without electromagnetic torque becoming negative.

The appearance of negative electromagnetic torque [2], [3] and motor operation above synchronous speed with normal voltage operation are addressed in [1], [3] but an adequate explanation of these phenomena was really missing. H. Rehaoulia and M. Poloujadoff [4] first came forward in mid eighties to suggest a logical way of thinking for a deeper understanding of transient motor behaviour during starting with balanced supply. It has been further elaborated by B. Basak, S Mallik and A. Rouf [5] under various load conditions identical to those as reported here but for starting with balanced supply voltages.

Comparing the results with those in [5] it is observed that the peak value of the torque transient during starting is more in case where one phase of the supply is interrupted during starting and this peak occurs after restoration of normalcy in supply. This can be justified by observing the current patterns Fig. 1(c), 2(c), 3(c) which increase again immediately after normalcy because of negative rotation of air gap field during single phasing.

It is well known that the air gap field of a balanced three phase induction motor operated from a balanced three phase supply is constant in amplitude and rotates at constant speed in a particular direction under steady state condition. In fact little information about the air gap field behaviour is available when the motor is subjected to various kinds of transient operations. In an attempt to study the motor performance during starting, the behaviour of transient air gap field is examined and reported in the figures 1(d), 2(d) and 3(d). These results indicate that transient air gap field

- i) is revolving with varying amplitude and speed
- ii) exhibits a reversal in its direction of rotation during first revolution
- iii) shows prominent elliptical nature during single phase operation which was absent in [5]

From the above loci an idea about the time taken by the air gap field to reach steady state speed can be made which appears to be largest in case of constant load indicating inertia and nature of load have a role in deciding the time.

In these figures evidence of reversal in the direction of rotation of air gap field during early part of starting period can also be observed. This may be attributed to current

modulation (the change in current unbalance) in phases during transient period of motor starting [5].

In order to explain how the concept of modulation is used in understanding the reversal of air gap field rotation let us have a look into the theory of electromagnetic power apparatus. It is known that the applied voltage and the air gap voltage in an induction motor will remain in equilibrium at steady state speed. Under this condition these two voltages have the same frequency and fixed magnitude which are, in fact, necessary conditions for a steady current flow in the motor winding. During the transient period the situation is somewhat different. A look into the motor starting process reveals that the air gap voltage is no longer constant during this period but it varies with the motor speed, in magnitude and frequency, until it attains the steady state speed. Thus, during the motor acceleration period there is always a voltage inequality that causes change in current magnitude to fulfill the condition of voltage balance.

Influenced by the air gap voltage the currents in each stator and rotor phase gets modulated both in amplitude and frequency although in different degree at any instant of time even under balanced supply condition. This is more severe when one phase of the supply goes out. Thus, a current unbalance does exist in the three phase system at any instant under consideration and this may be broken down in positive and negative sequence instantaneous currents. As a result, both forward and backward rotating field will be produced and depending upon their strength at that instant the direction of rotation of the resultant air gap field will be determined.

Moreover, it is observed in Fig. 1(b), 2(b) and 3(b) that the number of oscillations manifested in air gap field speed depends on inertia of the drive system, load on shaft, type of load and switching interruption. During the early part of starting period the number of oscillation is more in the cases under study than under normal operation [5]. Moreover, under same supply condition this number is less on no load, as compared to that on fan type load and further more at constant load. As the shaft load increases, the motor speeds up slowly, current modulation takes place over a greater length of time, thus increasing the number of oscillations. Similar comments can be made in case of inertia. Higher the inertia larger will be the number of oscillations.

A few intervals are observed in the speed time curves where the rotor speeds are found to drop. This is mainly due to the transient negative electromagnetic torques appearing in those intervals. A careful look at the air gap field speed reveals two facts (i) that during those intervals the rotor speeds are more than the field speeds and also the direction of field rotation is reversed - a fact leading to generation of negative electromagnetic torque (ii) that the rotor response to negative torque is not instantaneous and this is because of rotor inertia.

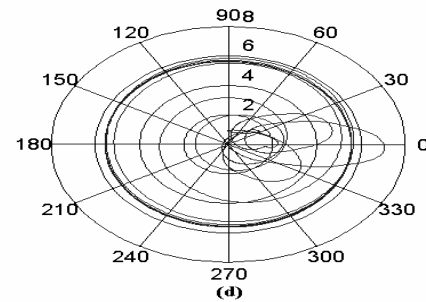
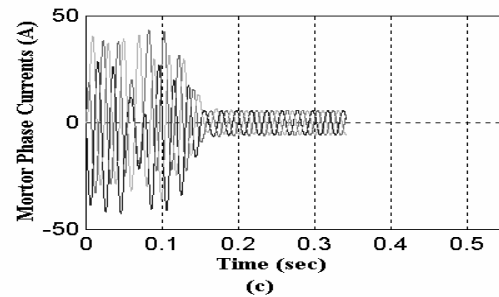
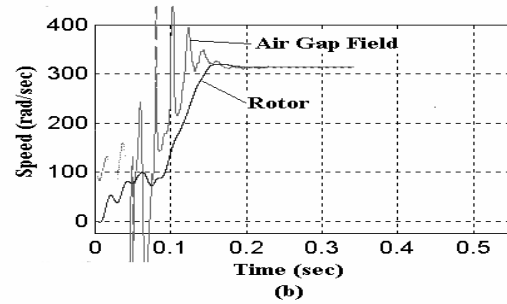
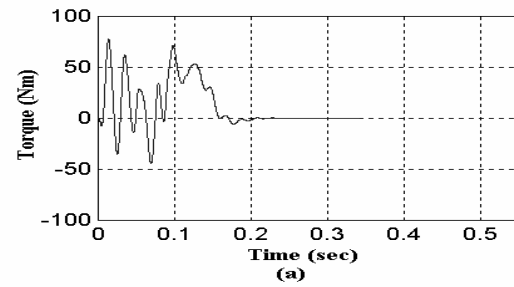
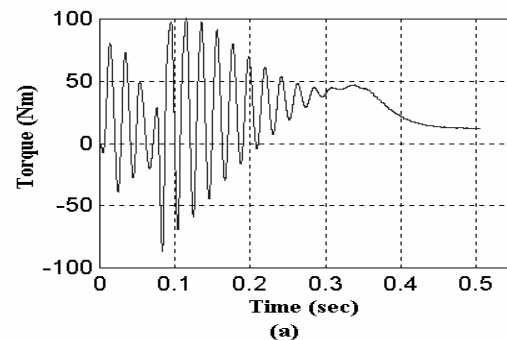

Fig. 1. Starting under no load having inertia $J=0.024 \text{ kgm}^2$ (a) Torque vs Time (b) Air gap field speed and Rotor speed vs Time (c) Motor currents vs Time and (d) Air gap field locus.



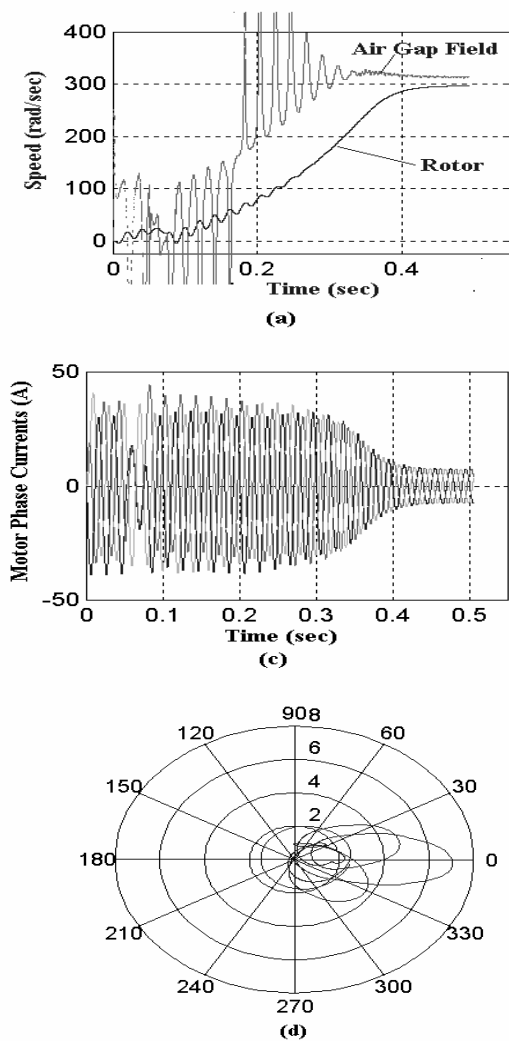

Fig. 2. Starting with constant load of 12 Nm having inertia $J=0.048 \text{ kgm}^2$ (a) Torque vs Time (b) Air gap field speed and Rotor speed vs Time (c) Motor currents vs Time and (d) Air gap field locus.

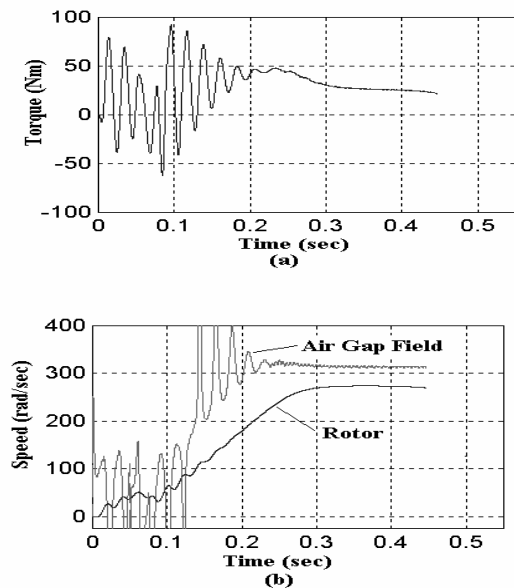

Fig. 3. Starting with fan type load of 12 Nm having inertia $J=0.048 \text{ kgm}^2$ (a) Torque vs Time (b) Air gap field speed and Rotor speed vs Time (c) Motor currents vs Time and (d) Air gap field locus.

IV. CONCLUSION

The starting performance of induction motor depends on the nature of supply as well as load. A study has been made for starting a three phase induction motor with different types of loads when one phase of the supply is interrupted for some interval duration starting process. The behaviour has been explained using concept of modulation. Higher transient torque is observed in case of supply disruption for small duration. The nature of variation of torque, speed and currents has been explained correlating with air gap field behaviour. In the model no load rotational losses has not been considered.

V. REFERENCES

- [1] Paul C. Krause. *Analysis of Electric Machinery*, McGraw Hill, International Edition, 1987.
- [2] A.W. Wahl & L.A. Kilgore, "Transient performance of induction motors", *AIEE Trans.* Vol. 39, pp. 603-607, 1940.
- [3] F.J. Maginniss & N.R. Schultz, "Transient performance of induction motors", *AIEE Trans.* Vol. 43, pp. 641-646, 1944.
- [4] H. Rehaoulia & M. Poloujadoff, "Transient behaviour of the resultant airgap field during run-up of an induction motor", *IEEE Trans. On Energy Conversion*, Vol. EC-1, No. 4, pp. 92-98, December 1986.
- [5] B. Basak, S Mallik & A. Rouf, "Transient performance analysis of induction motor during starting", *Proc. International Power Engineering Conference, IPEC 2001*, Singapore, pp. 365-369, May 2001.
- [6] S.A. Nasar & I. Boldea, *Electric Machines, Dynamics and Control*, CRC Press Inc. 1993