

## RECENT DEVELOPMENTS IN THE USE OF ADVANCED COMPOSITE MATERIALS FOR SEISMIC RETROFITTING

José I RESTREPO<sup>1</sup>, Yung-Chih WANG<sup>2</sup>, Paul A WYMER<sup>3</sup> And Rob W IRWIN<sup>4</sup>

### SUMMARY

Many reinforced concrete buildings and bridges built prior to the mid 1970s in seismic prone locations of the world may require retrofitting if they are to survive a strong seismic event without collapse. Advanced Composite Materials (ACMs) offer the versatility and ease of application at an economical cost to carry out seismic retrofitting in those regions of the critical elements that are deficient. This paper discusses ongoing research work at the University of Canterbury, New Zealand.

### INTRODUCTION

For many years structural engineers have designed building structures in seismically prone locations of the world for lateral loads that are significantly less than those required to ensure elastic response. As a result, critical regions of the lateral load resisting elements are expected to undergo inelastic excursions and dissipate energy. If these regions are to perform adequately they must be detailed for ductility. While the concept of inelastic response was known since the late 1950s, reinforced concrete building codes only began to incorporate design requirement to achieve ductility in the 1970s. For example, the American Concrete Institute building code, ACI 318-71 [ACI-318, 1971], following the San Fernando Earthquake of 1971, introduced seismic design recommendations by requiring the detailing for ductility of those regions in the earthquake resisting structural system assumed to be critical. The use of closely spaced transverse reinforcement at the beam and column ends were some of the main significant changes introduced in the design for ductility. In the 1970s the ACI 318-71 building code became accepted as a model code in many seismic locations of the world.

It is now known that buildings designed according to ACI 318-71 may not perform adequately during strong earthquakes. Recent seismic events and experimental work have shown that shear failures, premature longitudinal bar buckling and lap splices are some of the most common deficiencies found in structures designed with this code.

In the last decade ACMs have become a valuable resource in forensic engineering for use in retrofit/strengthening schemes. The most commonly used materials are glass and carbon fibres, which are embedded in an epoxy resin matrix. Comprehensive research work has been carried out on the use of ACMs for the seismic retrofit of bridge structures [Priestley et al., 1996] but the research work conducted on full scale structural components of buildings is rather limited up to the present time.

This paper discusses two uses of ACMS in building components. The experimental work is presented in this paper.

<sup>1</sup> Senior Lecturer, Department of Civil Engineering, University of Canterbury, New Zealand

<sup>2</sup> PhD Candidate, Department of Civil Engineering, University of Canterbury, New Zealand

<sup>3</sup> Northern Regional Manager, Construction Techniques Ltd, New Zealand

<sup>4</sup> Managing Director, Construction Techniques Group Ltd, New Zealand

## CONFINEMENT OF RECTANGULAR COLUMNS

The lack of closely spaced transverse reinforcement in columns has been one of the most common structural deficiencies found in older reinforced concrete buildings. Insufficient transverse reinforcement in the way of closed hoops and cross ties has shown to lead to a reduced rotation capacity in the plastic hinges due to three main causes: (i) buckling of the longitudinal reinforcement upon spalling of the concrete cover, (ii) poor confinement of the concrete core and (iii) premature shear failures.

An investigation was conducted to establish the benefits of wrapping rectangular columns with different layers of ACMs. The investigation was aimed at understanding the confinement effects of an elastic perimeter confining jacket in enhancing the ultimate stress and strength of the concrete, as well as providing information about preventing premature longitudinal reinforcing bar buckling.

It is well known [Park and Paulay, 1975] that the concrete core in circular columns can be efficiently confined with perimeter hoops. However, the confinement using perimeter hoops in square and rectangular columns is less efficient due to the formation of horizontal arching between the corner columns (Figure 1). Theoretical considerations to establish the efficiency of such confinement arrangement are given elsewhere [Wang and Restrepo, 1996].

Two series of tests comprising three square and three rectangular columns were tested under concentric axial load. Figure 2 depicts general reinforcement details of the test units. The first series, Series CS, comprised 300 mm square columns whereas the second series, Series CR, comprised 300 mm deep by 450 mm wide rectangular columns. The height of the concrete portion of the columns was 900 mm.

The longitudinal steel ratio for the columns was 1.5%. The longitudinal bars were Grade 430 steel, with a measured yield strength of 439 MPa. 10 mm diameter Grade 300 steel hoops and ties, with a measured yield strength of 305 MPa, were spaced 180 mm apart to simulate the old construction custom in seismic locations. With such hoop spacing, premature buckling of the longitudinal bars was expected to occur upon a strain reversal from a tensile strain excursion beyond the elastic range. The concrete cover to the side of the hoops was 30 mm. All units were cast simultaneously. Columns CS0 and CR0 were not jacketed and were used as control specimens. Two and six TYFO S ACM wraps of 1.27 mm thickness were applied to the second and third columns (Columns CS2 and CR2, and Columns CS6 and CR6). TYFO S is an ACM reinforced primarily in one direction. The extent of the ACM jacket is depicted in Figure 3.

Figure 4 illustrates the instrumentation of the columns for determining lateral and transverse strains. The longitudinal strain was monitored by four 30 mm travel linear potentiometers with 450 mm gauge length. The lateral strain was measured with DEMEC gauges only in the test units with jackets. Concentric tension and compression loading was applied by a 10 MN capacity DARTEC universal testing machine. The columns were bolted to grips with spherical bearings. The axial load was applied in small increments at a strain rate of about  $1 \times 10^{-5}$  per second. Figure 5 depicts the loading history.

The measured elastic modulus and ultimate tensile strength in the main direction of the ACM was 19.7 GPa and 375 MPa, respectively. The concrete compressive strength, obtained from columns CS0 and CR0 when loaded to 0.2% compressive strain, was 18.9 MPa.

Figure 6 (a) shows the axial load versus axial strain behaviour of columns CS0, CS2 and CS6. The envelope of the compressive load is shown in bold for clarity. It is evident in this figure that both the strength and the deformation capacity of the columns increased when increasing the jacket thickness.

The longitudinal bars in column CS0 buckled, as expected, and induced spalling of the concrete cover upon reversing from the tensile strain excursion. The compressive axial load decreased rapidly after a compressive strain of 0.2%. The results obtained from the test in column CS2 demonstrated the efficiency of the jacket in preventing early buckling of the longitudinal bars from occurring. The concentric compressive load was maintained up to a compressive strain of 2%. The mode of failure was by delamination of the wraps. Delamination of the jacket commenced at a compressive strain of 0.8% and slowly progressed until it became unrestricted at 2% strain. Column CS6 showed remarkable behaviour. The concentric load was not only maintained but increased to almost twice the load of the unwrapped column. Failure occurred when the jacket split at one of the corners at a very large strain of 4.3%.

The tests on the oblong columns showed similar trends and behaviour to the tests on square columns. Figure 6 (b) plots the concentric load versus axial strain response for columns CR0, CR2 and CR6. The main difference in the overall response observed is between columns CR6 and CS6. Unit CR6 did not show the same strength increase as Unit CS6. This column failed by splitting of the jacket at a compressive strain of 2.8%. The main reason for the difference in behaviour is due to the poorer confinement effect exerted by the jacket in oblong columns, which is caused by the larger extent of the horizontal arching between the column corners.

The experimental evidence obtained from these series of tests show that ACM jackets provide excellent confinement to square reinforced concrete columns, and to a lesser extent in rectangular columns, increasing both the ultimate strength and strain. Compressive strains of at least 2% were measured without significant loss of the load carrying capacity in tests on columns with a minimum of two wraps. Larger strains were recorded when the number of wraps was increased from two to six. The jackets also prevented the buckling of the longitudinal bars.

### USE OF COMPOSITE PLATES IN BEAMS WITH BAR CURTAILMENT DEFICIENCIES

An aspect ignored in the earlier seismic design codes was the participation of the slab longitudinal reinforcement in augmenting the negative flexural strength of beams of moment resisting frames designed to provide the earthquake resistance. The main problem when ignoring the participation of the slab reinforcement is that the curtailment of the beam reinforcement and the transverse reinforcement provided for shear resistance may be inadequate. Nowadays, modern codes require that the contribution of the reinforcement in cast-in-place concrete solid slabs be assessed and be accounted for in design [SANZ, 1995]. It can be shown, especially in the upper floors of buildings where the slab contribution is more significant in relative terms, that the critical region for the development of a negative plastic hinge may not occur at the beam ends but at a distance away towards midspan. The relocation of the critical region implies that plasticity may develop where no special detailing for ductility has been provided. Such beams may fail in a rather brittle manner and may also fail at a load level less than that required to attain the flexural strength when accounting for the longitudinal reinforcement of the beam alone.

To highlight the possible deficiency induced by the slab reinforcement, an eight storey building was designed following the ACI 318-71 building code seismic design recommendations [ACI-318, 1971]. The primary earthquake resisting system of the building was formed by a grid of moment resisting frames spaced at 5.5 m and 5.0 m in two orthogonal directions. The slab was designed to transfer gravity loading by two-way action. A study of the collapse mechanism in this floor indicated that negative plastic hinges would not form at the beam ends due to the reinforcement arrangement in the slab and the curtailment of the longitudinal reinforcement in the beam.

Two identical full-scale beam subassemblies of the building were built and tested under reversed cyclic loading conditions simulating seismic loading. Figure 7 shows reinforcing details of the units tested. Three tests were performed in the two units:

*Test Unit T1 - Stage 1* to observe the seismic performance of the “as-built” unit

*Test Unit T1 - Stage 2* to observe the seismic response of a beam retrofitted after being initially damaged

*Test Unit T2* to observe the seismic performance of a beam retrofitted before being damaged

The concrete compressive strength at the day of testing, measured using 100 mm diameter by 200 mm high cylinders  $f'_c$ , was 24 and 18 MPa for units T1 and T2, respectively. This relatively low strength concrete was deliberately chosen, as it would provide a worst case scenario. The measured yield strength of the deformed 28, 24 and 12 mm diameter bars was 316, 320 and 316 MPa, respectively. The measured yield strength of the 10 mm diameter plain round stirrups was 354 MPa. The units were repaired and retrofitted using TYFO S e-glass ACM plates of 1.27 mm thickness. The measured tensile strength and elastic modulus of the plate in the main direction of the fibres was 387 MPa and 18.7 GPa, respectively.

Figure 8 shows the test set-up. Load controlled cycles were initially imposed to the units to find the secant stiffness and vertical displacement at 75% of the estimated capacity of the unit. Displacement controlled cycles were applied to the units when loaded beyond the elastic range. The cycles were controlled in terms of the displacement ductility  $\mu$ , which is defined as the ratio between the applied vertical displacement,  $\Delta$ , and the

vertical displacement at first yield,  $\Delta_y$ . The vertical displacement at first yield was defined as 4/3 times the vertical displacement observed in the load controlled cycles to 75% of the capacity of the unit [Paulay and Priestley, 1992]. Vertical displacements were measured at the point of application of loading with any component of vertical displacement due to the rigid body rotation of the column stub being removed.

Figure 9 shows the vertical load vertical displacement of the test units. The test units behaved as expected when loaded upwards. A positive plastic hinge formed in the beam at the column face and extensive yielding of the beam bottom longitudinal reinforcement was observed in this region. The measured and predicted capacity agreed very well, as anticipated.

Under downward loading, cracking in the beam extended from the column face to near the point of application of loading. When the beam was pushed into the inelastic range, a large diagonal crack inclined at 42 degrees to the horizontal opened up at 1.3 m from the column face. The beam top longitudinal reinforcement remained elastic at the column face but yielded in the region at and adjacent to the large diagonal crack. Note that there are no closely spaced stirrups in this part of the beam. Further downward cycles resulted in extensive yielding of the stirrups and crushing of the concrete in this region. It is apparent in Figure 9 (a) that the negative flexural strength, calculated at the face of the column and taking into consideration the slab reinforcement, was not attained. At minus 1% drift angle the capacity of the beam had begun to drop due to an imminent flexure-shear failure. This drift angle, and the observed damage, was considered to be the limit at which a satisfactory repair scheme could be carried out in a structure. Consequently, the test was halted and the repair work conducted.

The damaged unit T1 was repaired by epoxy injecting the main cracks, by applying two 1.38 m wide strips of TYFO S ACM on the slab and on the sides of the beam at the damaged region. Figure 7 illustrates details of the repair work with bonded plates. The concrete surface where the plates were to be bonded, was ground to remove any laitance and then cleaned with oil-free air pressure. A thick layer of epoxy adhesive was applied to the concrete surface before bonding the plate. Since the interface bond between the ACM plate and the concrete surface was considered critical, care was taken to ensure that the steel plate at the point of application of downward loading would transfer the load directly onto the beam without clamping the bonded plate. Unit T2 was retrofitted in the same manner as unit T1.

The aim of the repair and retrofit work carried out with the 1.38 m wide ACM plates was to force a negative plastic hinge to form at the column face, where closely spaced stirrups had been provided. Forcing the plastic hinges at the beam ends also reduces the plastic rotation demand in both the positive and negative plastic hinges in the bay of the frame. The repair/retrofit work was done by providing additional passive flexural resistance to the beam throughout its length, except at beam ends. Consideration was given during the design of the repair/retrofit scheme to limiting the longitudinal tensile strain in the plate bonded to the slab to 0.4%, and also to limiting the bond stress between the plate and the concrete to be less than  $0.17(f'c)^{1/2}$  [MPa]. The tensile strain limit was chosen to avoid premature deterioration of the shear strength mechanism in the beam where the longitudinal reinforcement had been cut-off. The bond stress limit was selected to avoid premature delamination of the plate. The three-sided layers of the ACM were designed to control the width of the diagonal cracks and hence, to delay the loss of the shear transfer mechanism through aggregate interlock.

The hysteretic response of the repaired unit T1 can be compared with the response of the prototype unit T1 in Figure 9. The strength and ductility increase is due to the plate bonded to the top of the beam and slab, which was very effective in forcing a negative plastic hinge to develop at the column face of the beam. A similar behaviour was observed for unit T2. The slab reinforcement was observed to yield across the full flange width in a yield line passing through the column face. This was also confirmed, as the theoretical capacity,  $P_n$ , accounting for all the slab longitudinal reinforcement, agreed very well with the measured load

In the tests with the bonded plates, delamination of the three-sided e-glass strips occurred in the region where the beam longitudinal reinforcement had been cut-off. This suggests that side strips bonded to the web of reinforced concrete beams may not be a reliable way to enhance the shear strength unless they are properly anchored to the beam sides. This has been subsequently confirmed in other testing carried out recently. The loss of the three-sided plates resulted in localized shear deformation which in turn caused the top plate to kink and eventually delaminate at 3% drift angle corresponding to a displacement ductility  $\mu = -3$ . The hysteretic response of the units can be considered satisfactory since drift angles of 2% were attained with minimum strength degradation. In conclusion, the effectiveness of composite material plates to provide additional flexural strength in beams with bar curtailment deficiencies was demonstrated in the experimental programme.

## SUMMARY AND CONCLUSIONS

Experimental work on the use of composite materials for the retrofit of structural components of older reinforced concrete building structures is described in this paper.

Laboratory testing on square and rectangular reinforced concrete columns with full scale cross sections and ACM jackets, showed the effectiveness of composite materials in enhancing the ultimate strain (ductility) and strength of concrete and their ability to prevent buckling of the longitudinal reinforcement.

Beams of moment resisting frames designed to earlier seismic design codes may show inadequate performance due to the presence of the slab reinforcement. Slab reinforcement may be a cause for poor development of the beam negative flexural reinforcement and may push the formation of the plastic hinges away from the column faces into a region not detailed for ductility.

Experimental work conducted on full scale beam/slab assemblies showed that ACM plates, acting as additional negative beam reinforcement, can successfully be used to relocate the negative plastic hinges to the column face. To ensure the adequate performance of the retrofit scheme, shear deformations in the beam must be kept to a minimum to reduce the kinking effect and potential delamination of the composite material plate.

## REFERENCES

ACI 318-71, American Concrete Institute, *Building Code Requirements for Reinforced Concrete*, Detroit, Michigan, 1971.

Park, R and Paulay, T, *Reinforced Concrete Structures*, John Wiley & Sons, 1975

Paulay, T. and Priestley, M.J.N., 1992, *Seismic Design of Reinforced Concrete and Masonry Buildings*, John Wiley & Sons, New York.

Priestley, M.J.N., Seible, F., and Calvi, G.M., 1996, *Seismic Design and Retrofit of Bridges*, John Wiley & Sons, New York.

SANZ, Standards Association of New Zealand, *NZS 3101:1995 Concrete Structures Standard, Parts 1 and 2*, 1995, Wellington.

Wang, Y.C. and Restrepo, J.I., "Strength Enhancement of Concentrically Loaded Reinforced Concrete Columns Using TYFO S Fibrwrap Jackets," Research Report 96-12, Department of Civil Engineering, University of Canterbury, Christchurch, 1996, 25 pp.

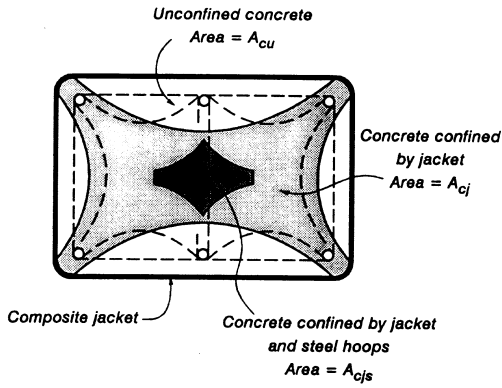

**Fig. 1 - Concrete Arching in Columns Confined with Composite Jackets**

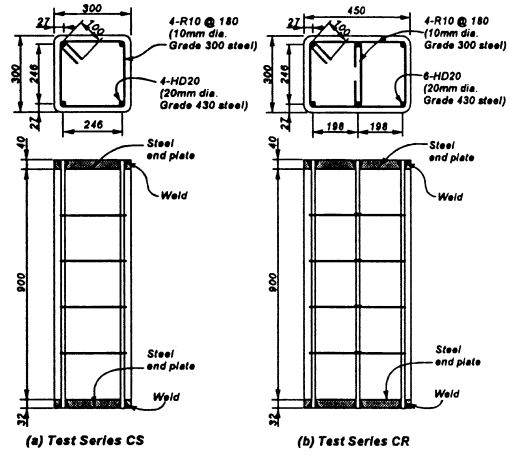

**Fig. 2 - Reinforcement of Column Units**

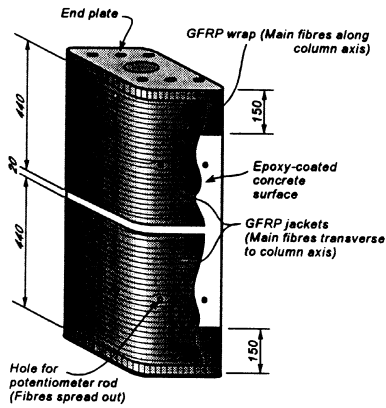

**Fig. 3 - Jacket in Column Units**

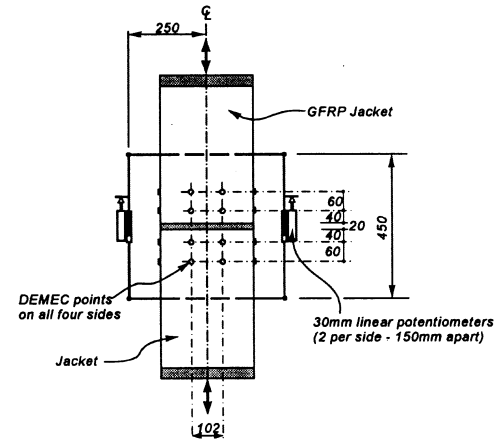

**Fig. 4 - Instrumentation**

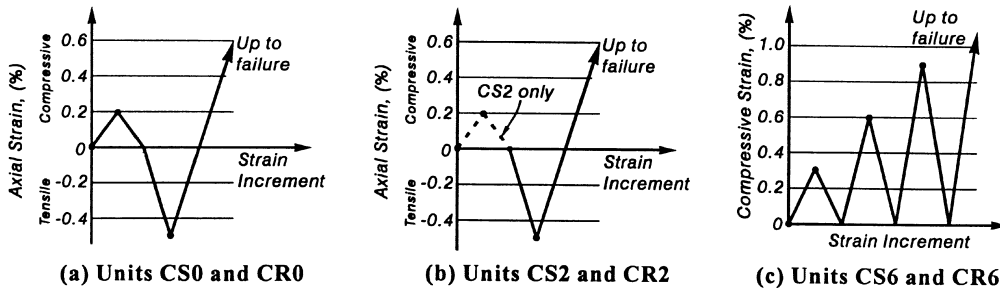

**Fig. 5 - Test Regime**

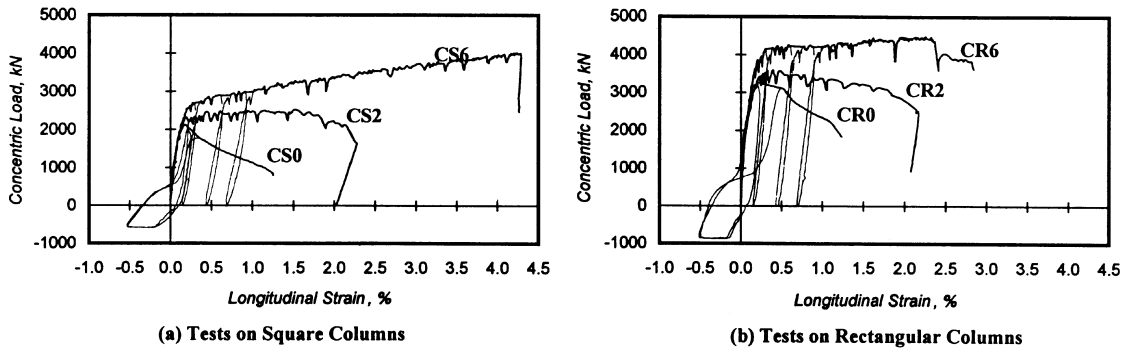

**Fig. 6 - Axial Load - Axial Strain Response**

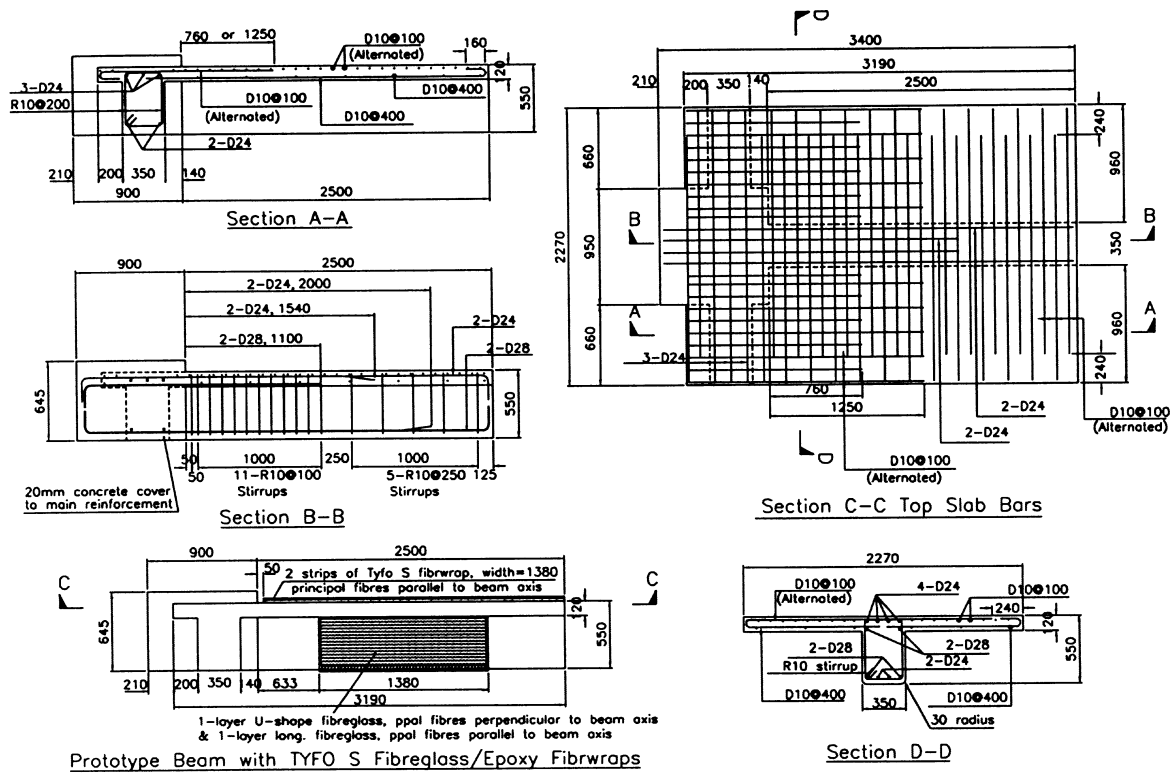

Fig. 7 - Reinforcing Details of Flange Beam Units

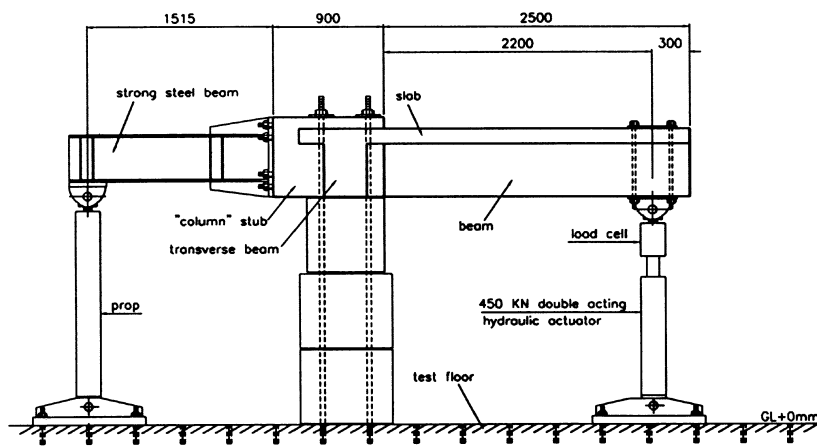

Fig. 8 - Flange Beam Units Test Set-up

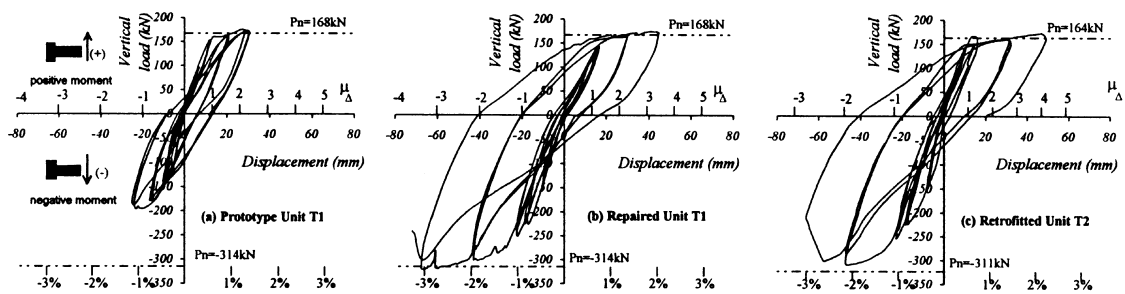

Fig. 9 - Measured Hysteresis Loops