

SOME FUNDAMENTAL ASPECTS OF TORSIONALLY COUPLED STRUCTURES

Juan C DE LA LLERA¹

SUMMARY

Buildings with coupled lateral and torsional motions are continuously cited as classical examples of structural damage during an earthquake. There is nothing intrinsically wrong with a coupled-structure that justifies such damage; rather, the problem is a poor estimation of the inelastic displacement demand of the resisting planes. Since, the three-dimensional inelastic behavior of a building is rarely used in the building design, approximate code procedures are used for estimating the demand. It is well recognized now that even for single-story structures, the inelastic seismic response is not amenable of being encapsulated into simple code-like rules. Consequently, one procedure for simplified analysis of such structures has been devised. This procedure is based on the use of an ultimate surface in the story shears and torque space. This surface is used in this paper to explain certain research results on the topic as well as to introduce some basic aspects of the inelastic behavior of torsionally-coupled structures. Two examples are presented in which these surfaces have been used in conjunction with a simplified structural model to compute the inelastic response of a base-isolated structure and a seven story reinforced concrete building.

INTRODUCTION

Lateral-torsional coupling in asymmetric-plan buildings leads inevitably to a non-uniform displacement demand among resisting planes. Because such demand is of great importance in the proper detailing of structural members, it should be predicted accurately in order to achieve a reliable design. In practice, this demand is the result of the inelastic behavior of the structure during an earthquake and should not be computed, as typically done, from procedures that assume an elastic behavior of the building.

Since the correlation between structural damage and plan asymmetry has been clearly established, the earthquake behavior of asymmetric-plan structures has been thoroughly studied over the last three decades. Most of these studies have looked for simple rules that would enable to account for the increase in displacement demand in the design. Although most of these results are supported by extensive and complete parametric studies, they present three important shortcomings. First, the results and conclusions obtained are model dependent and, hence, the rules proposed. Second, the extension between the inelastic behavior of single-story buildings to multistory buildings is not exempt of serious difficulties. And third, even for a specific single-story structural model, there are no simple and general trends in the results

In the study of plan-asymmetric structures, the problem has been traditionally separated into two parts, accidental and natural torsion. The latter is the result of the inherent asymmetry in stiffness and resistance of resisting planes as conceived intentionally by the designer, or better, as forced by architectural reasons in most cases. As opposed to this intentional asymmetry, accidental torsion is the result of all factors that cause asymmetry in plan which are not accounted for in the analysis, such as variability in stiffness and mass. In real life situations, although convenient, both effects cannot be split, not even for the elastic behavior of the structure. The reason they are split in two different phenomena is mainly analytical. Accidental torsion must be treated

¹ Dept of Structural & Geotechnical Engineering, Universidad Católica de Chile, Santiago, Chile Email: jcllera@ing.puc.cl

necessarily under a statistical framework; natural torsion can be treated by conventional deterministic procedures.

Currently, there are three alternatives to consider the effects of plan asymmetry in building design. First, the designer may use one of the many simplified rules existing in different building codes, recognizing that they have serious problems and that may not provide a safe estimate of the building displacement demand.

A second possibility is that the designer uses a three-dimensional non-linear analysis program, in which case the inelastic (natural) torsion will be automatically accounted for. Although in the author's opinion this should naturally be the future solution of the torsional problem, there are some practical aspects that keep inelastic dynamic analyses a bit ahead of the current engineering profession. Some of these aspects are related to the software itself, such as its availability and high input/output processing cost, and others to the profession and code writing entities, such as the slow evolution of our seismic codes in that direction.

The third possibility is to perform a nonlinear dynamic analysis of the structure using a simplified model capable of representing the most important features of the inelastic behavior in plan of the structure. One such model was presented earlier for mono-symmetric structures [De la Llera and Chopra, 1994] and consists of representing by single super-elements each building story in the so-called single element model (SEM). The elastic properties of the super-elements are selected in order to match closely the elastic behavior of the structure; the inelastic properties of the super-elements are based on the Ultimate Story-Shear and Torque surface (USST), which represents static combinations of story shear and torque that produce a story mechanism.

Although the SEM leads to an approximation of the force-deformation characteristics of a building story, it has certain advantages over the full three-dimensional nonlinear model of the building. For instance, it enables to predict the mechanisms that govern the inelastic behavior in plan before a dynamic analysis is performed. It also helps in visualizing quickly the effect of stiffening or strengthening a resisting plane. Finally, it is so cheap computationally that allows trying a number of different structural configurations at the initial stage of a project in order to select the optimal one. Although this article is devoted to discuss certain general aspects of the torsional behavior of structures, each argument will borrow some aspects of the USST surface since it provides a sufficiently general framework to explain the inelastic torsional behavior of buildings. For the sake of brevity and since the properties of the USST surfaces for mono-symmetric structures have been presented elsewhere [De la Llera and Chopra, 1994], the paper assumes certain familiarity with these surfaces.

2. STRUCTURAL MODEL

Before discussing certain important results in torsion, it seems necessary to adopt a convention to denote the models considered. Hereafter the pair (N_x, N_y) denotes a structural system with N_x and N_y resisting planes in the x- and y-direction, respectively. Further, it is assumed a rigid diaphragm in the model, which is characterized by two horizontal translations and the rotation in plan.

The equations that govern the motion of the structure can be stated as

$$M\ddot{q} + C\dot{q} + R(q, \dot{q}, t) = L_u \ddot{u}_g(t)$$

where $R(q, \dot{q}, t)$ represents the force vector of story-shears and torque collocated on the degrees of freedom of each floor diaphragm. On the other hand, M , C , and L_w are the well known mass, damping, and input collocation matrices. It is interesting to emphasize that the SEM model proposed is nothing but a procedure to compute an approximation of the restoring force vector $R(q, \dot{q}, t)$. In the linear case, $R(q, \dot{q}, t) = K_l q(t)$, where K_l is the lateral stiffness matrix of the building and $q(t)$ the dynamic degrees of freedom. In the non-linear case, $R(q, \dot{q}, t)$ represents the assembly of the story-shear and torque forces acting on each floor computed from the USST surfaces.

3. CONSTRUCTING THE USST SURFACES

Rules are presented next to construct the USST surfaces for asymmetric-plan buildings. These rules are an extension of the rules presented earlier for mono-symmetric structures [De la Llera and Chopra, 1994]. The details and proofs of these properties are skipped in this presentation.

The USST surface is the locus of the story-shear and torque combinations that applied statically onto the story produce a mechanism. Therefore, no combination of shear and torque can go beyond this surface; plastic behavior is represented in this force space as motions along the surface. Notice that plastic deformations can occur even when there is no motion along the USST surface. Thus, the inelastic deformation cannot be computed from the USST surface unless a step-by-step static or dynamic analysis is performed.

Different procedures may be used to construct the 3D-USST surface for a given story; the simplest approach is to use the concept of the Center of Plastic Rotation (CPR). To ease the explanation, let us consider the example presented in Figure 1. It can be shown that the CPR will be located at the intersection of the two resisting planes that remain elastic for a given mechanism for which the elasto-plastic operator is of rank 2. At the intersection of the lines of action of two resisting planes (1-A) we may consider a double spring element with no interaction as indicated; both resisting planes are equivalent to this element. Let us draw a small circle around this intersection and determine the region of the USST surface generated for all combinations of elastic shears in planes 1 and A.

To visualize this region it suffices to study the case when the CPR is located anywhere in the first, second, third, and fourth quadrants. As shown in the figure, this will lead to four combinations of story shear corresponding to the plus and minus values of the shears in planes 1 and A. If the CPR is in the second quadrant (a), the vertex of the surface corresponding to plus shear values in the two planes, (+,+), will be generated. Similarly, locating the CPR in the fourth quadrant will lead to the (-,-) vertex (c), and so on. It is possible to prove that if one travels sequentially the vertices of the shear interaction corresponding to the intersecting planes, the vertices of the USST surface will also be generated sequentially. Also notice that the forces in all other resisting planes remain the same despite the changes in the position of the CPR on the small circle around the intersection 1-A. The resulting 1-A planar surface is presented schematically in the figure. As in the 2D-case, the projections on the (V_x, V_y) plane of the edges of the generated face are always twice the shear capacity of the elements. Thus, knowing one vertex of the face the others can be computed by adding and subtracting the capacities of the intersecting planes. The resulting USST surface for the building example is also presented in the figure.

The procedure presented for a single face can be used to determine all other faces of the USST surface and can be codified for nonlinear analysis in a program such as MATLAB. Just as a summary of this section, the most relevant properties of the three-dimensional USST surface are stated next:

1. The 3D USST surface is formed by planar faces with four vertices each. Each planar face on the USST surface corresponds to a mechanism of the structure in which at most two resisting planes elements are elastic; the edges correspond to mechanisms in which only one of the two planes is elastic, and vertices are combinations of shear and torque for which all planes are plastic.
2. These planar faces have projections that are parallel to the coordinate axes (V_x, V_y) , as a result of the lack of shear interaction among planes. Therefore, none of the surface edges may have an oblique projection. Moreover, no vertical edges may exist since a change in torque necessarily implies a change in shear.
3. The length of the projection of the edges in the (V_x, V_y) plane is always twice the capacity of the element that remains elastic for the corresponding mechanism.
4. The slopes of each planar face with respect to the coordinate axes (V_x, V_y) correspond to the location of the intersection point of the lines of action of the resisting planes that remain elastic, i.e., the coordinates of the CPR.
5. The planar faces are ordered in space, i.e., adjacent CPR's generate adjacent faces of the USST surface.
6. Vertical faces of the USST surface correspond to mechanisms in which all elements in one direction are yielding; the torque varies just as a result of the variation in the forces of the planes in the orthogonal direction. These faces limit the USST surface and have as many vertices as twice the elements in the direction normal to the face.

4. SOME IMPORTANT RESULTS

It is interesting to use the conceptual framework developed by the USST surfaces to explain some of the more general results attained by previous research as well as some of the apparent contradictory conclusions. Let us focus first on those issues related to the displacement demand.

"With increasing inelastic action, the element deformation in an asymmetric-plan system becomes closer to that of the symmetric-plan system" [Goel and Chopra, 1990]. This implies that the torsional response decreases as the inelastic behavior of the structure increases. In other words, the inelastic rotations are locked in such case, leading to a system that resembles more one with a symmetric-plan than one with an asymmetric-plan. This conclusion however is opposed to the results obtained in another research that concludes that *"...sizable rotational motion is involved at the instant when peak ductility demand is reached"* [Tso and Sadek, 1983]. Then, the question is how large is the rotational motion when the peak displacement is reached in the building?. It turns out that the apparent contradiction in these two results is not such and it can be explained using the USST surfaces. The first point is to realize that these two studies used a (2,3) and (0,3) model, respectively. Although both models may have a similar elastic behavior, they definitely have a completely dissimilar inelastic behavior as a result of the existence (or not) of resisting planes in the direction perpendicular to the direction of ground motion. A mono-symmetric model with resisting planes in the direction perpendicular to the direction of ground motion such as the (2,3) model presents vertical faces of the USST surface at the maximum base shear. This implies that there are a number of mechanisms that are predominantly translational which do not involve important inelastic rotation in the small torque region; those are the mechanisms that controlled the responses of the first study. On the other hand, the (0,3) model involves only torsional mechanisms at the low torque region and hence inelastic rotations will essentially always be present, explaining the discrepancy. The question is which model should be used for practical engineering purposes.

The answer to this question depends exclusively on the level of yielding expected for the resisting planes in the orthogonal direction. It is assumed that the analysis is still that of a mono-symmetric structure and, hence, a single component of ground motion is considered. If large ductilities are expected in the perpendicular direction, say 8 or 12, the contribution of the resisting planes in that direction should be omitted in order to estimate the displacement conservatively. Otherwise, fictitious elastic locking will occur with the inelastic rotation. If for some intended reason, the yielding in the perpendicular direction is expected to be small, say ductilities of 2 to 3, the contribution of perpendicular planes may be beneficial in restraining the inelastic rotation.

This issue also leads to an interesting concept. Suppose we have a nominally symmetric structure. If the components of ground motion in both principal directions are such that cause substantial yielding of the building, the resisting planes in a given direction will tend to yield in that same direction. This implies that the combinations of strongest story shear and torque will occur on the exterior faces of the USST surface; those were we have the maximum shear. Since these external faces cannot present a region of the surface with predominantly translational mechanisms, except for a single mechanism at zero torque, it occurs that any accidental disturbance will take the structure off the nominal symmetry and lead it to a torsional mechanism. Therefore, in conditions of important yielding, nominally symmetric structures will develop torsional mechanisms also and yielding will concentrate in one resisting plane more than others. The resulting increment in displacement demand should be considered in the design of the building. In the author's opinion, the seismic behavior of the Van Nuys building during the Northridge earthquake experienced this behavior. Perimeter frame structures are particularly prone to this behavior. Moreover, due to the large distance among resisting planes in many cases, large inelastic rotations occur that are not accounted for in current analysis and code procedures.

Because of the locking of inelastic rotations produced in structures with resisting planes in the orthogonal direction, the importance of these planes has been over emphasized. *"...The inelastic response of systems is influenced significantly by the contribution to the torsional stiffness from the resisting elements perpendicular to the direction of ground motion"* [Goel and Chopra, 1990; De la Llera & Chopra, 1994] and *"...torsional rotations and the formation of a torsional mechanism strongly depend on the structural elements which resist loads in the direction perpendicular to the direction of the applied loading"* [Kilar and Fajfar, 1997]. As stated above, if yielding is reduced in the orthogonal planes, more of the locking effect will be observed. For any structure in practice, however, the incidence angle of the input motion is in most cases random. Hence, increasing the

strength of the orthogonal resisting planes implies increasing the strength of the whole structure. Although valuable in many cases, such increase in strength is not a direct countermeasure to torsion.

When using the USST surfaces to compute the inelastic displacement demand, it is necessary to realize that the history of deformations is important. Effects such as the freezing of elastic deformation in vertices of the surface need to be identified and considered. Such freezing is not a result of the singularity of the vertex; it would also occur if the surface had a continuously differentiable round shape with large curvature. Besides, during an integration interval, the mechanism developed by a structure may switch as a result of yielding along the USST surface.

Another debated aspect is relative to the location of the center of stiffness (CS) and the center of resistance or strength (CR) relative to the CM. *"As it would be physically expected the use of resistance eccentricity with the same sign as the static eccentricity improves the torsional behavior of structures"* [Sedarat and Bertero, 1990]. This conclusion is not valid in general. When the CM is in between the CS and the CR and it is moved toward the CR, the increasing eccentricity between the CM and CS induces positive correlation between the story shears and torque. Thus, they will tend to be located in the first and third quadrants of the USST surface. Since the USST surface is also skewed toward these quadrants, the inelastic behavior of the structure will occur close to the predominantly translational mechanisms (vertical branches) and, hence, the torsional effects decrease. Otherwise, if the CS and CR are on the same side of the CM, increasing the eccentricity by displacing the CS toward the CR will cause that the story shear and torque combinations be located in the even quadrants, which are controlled by strongly torsional mechanisms. In summary, in most cases it is convenient that the CS and CR be on opposite sides of the CM; this can be accomplished by the use of frictional devices.

5. DISCUSSION OF DESIGN ASPECTS

To consider the effects of lateral-torsional coupling in structures the following scheme is proposed:

1. Compute the nominal capacities for all structural elements associated to the true axial loads; in columns, for instance, those produced by the combination of dead loads and the ultimate shears in coupled beams reaching the column or wall.
2. Associate a kinematically compatible mechanism for all resisting planes. For instance, select a strong-column-weak-beam type of behavior and first-floor hinges in all vertical elements. In some cases, localized story mechanisms may be more appropriate, or if available, the shears resulting from a planar pushover analysis of the resisting planes. In either case, the objective is to define the nominal shear capacities of each resisting plane associated to a credible mechanism.
3. Construct the nominal USST surfaces for each story using the capacities of each resisting plane.
4. Analyze the structure dynamically using the super-element model (SEM). Knowing the deformations of the SEM, compute the deformations of each resisting plane by using the rigid diaphragm assumption.
5. Redesign the capacities of resisting planes in order to balance the torsional behavior using the general guides provided by the properties of the USST surfaces.

In some cases, the localized increase in element deformations caused by plan asymmetry may be corrected by modifying the stiffness and strength of resisting planes. In general, this is accomplished by directing the inelastic plan behavior represented by the story-shears and torque to the region of the USST surface controlled by predominantly translational mechanisms. In case that the modifications in conventional members do not suffice, the easiest way to alter the USST surface is through the use of frictional devices which allow to separate clearly stiffness from strength.

Another effective technique to correct torsional problems in buildings is base isolation. An example is presented in Figure 2. This is a new building in the city of Santiago that has been considered as a candidate for

base isolation. The plan is asymmetric, but more important, since the building plan is rather long, the slightest superstructure eccentricity leads to large discrepancies in displacement demand among resisting planes. Such behavior has been corrected using high damping isolators with different stiffnesses and the USST concepts; another effective way would have been through the use of frictional pendulum devices. As shown in the figure the effect is dramatically reduced by the appropriate selection of isolators.

6. USE OF THE USST SURFACES ON A REAL BUILDING

Just as an example of the use of the USST surfaces and the SEM, the inelastic behavior of a seven R/C building damaged during the Northridge earthquake was considered (Figure 3). Because of the space limitations, only the USST surfaces are presented. The building was subjected to the two horizontal components of the Sylmar record in order to show the result of important inelastic excursions of the structure.

Perhaps the most important observation regarding this figure is that yielding occurs on the external faces of the USST surface as noticed earlier. Yielding on those faces necessarily implies that torsional mechanisms are developed even though the structure is nominally symmetric. The model considered the cracking of the fourth floor columns as an accidental effect that causes the eccentricity observed in the nominal model; such accidental eccentricity could have been triggered also by an existing partition wall in the first-story of the building. As shown in the plots of story shear, this small accidental eccentricity causes that the yielding of the building localizes mainly in two resisting planes.

ACKNOWLEDGEMENTS

This work was sponsored by the Chilean National Fund for the Foment and Development of Technology, FONDEF, under Grant N° D96I1008 and the National Fund for Science and Technology, Fondecyt under Grant N° 1960358. The author is grateful for this support.

REFERENCES

- De la Llera, J.C. and Chopra, A.K. (1994), "Accidental and Natural Torsion in Earthquake Response and Design of Buildings", *Report N° UCB/ERC-94/07*, Earthquake Engineering and Research Center, University of California, Berkeley.
- Kilar, V. and Fajfar, P. (1997) "Simple Push-over Analysis of Asymmetric Buildings", *Earthquake Engineering and Structural Dynamics*, 26.
- Goel, R. K. and Chopra, A.K. (1990), "Inelastic Seismic Response of One-Story, Asymmetric Plan Systems", *Report N° UCB/ERC-90/14*, Earthquake Engineering and Research Center, University of California, Berkeley.
- Sedarat, H. and Bertero, V. V. (1990), "Effects of Torsion on the Nonlinear Inelastic Seismic Response of Multi-Story Structures", *Proceedings of the 4th U.S. National Conference on Earthquake Engineering*, Palm Springs, California, 2, 421-430.
- Tso, W.K. and Sadek, A.W. (1985), "Inelastic Seismic Response of Simple Eccentric Structures", *Earthquake Engineering and Structural Dynamics*, 19.

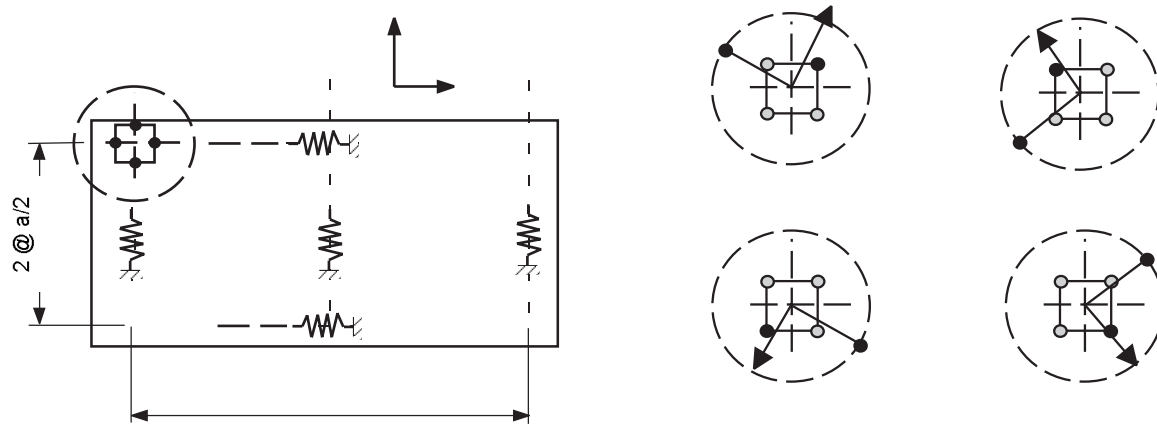

Figure 1 Construction of the 3D-USST surface for the building example using the center of plastic rotation.

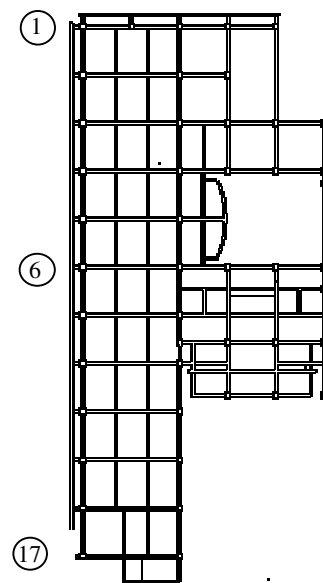
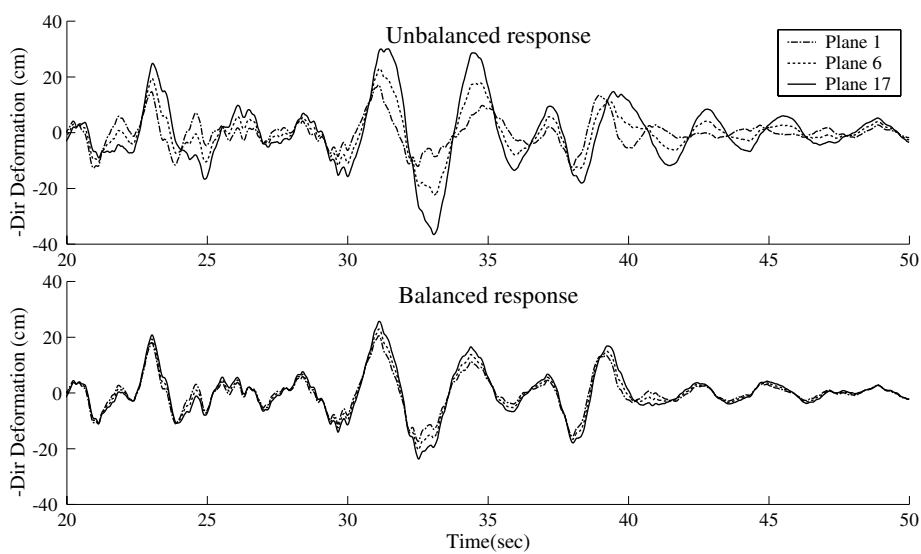

Figure 2 Balanced and unbalanced torsional effects on a base isolated building using high damping rubber bearings.

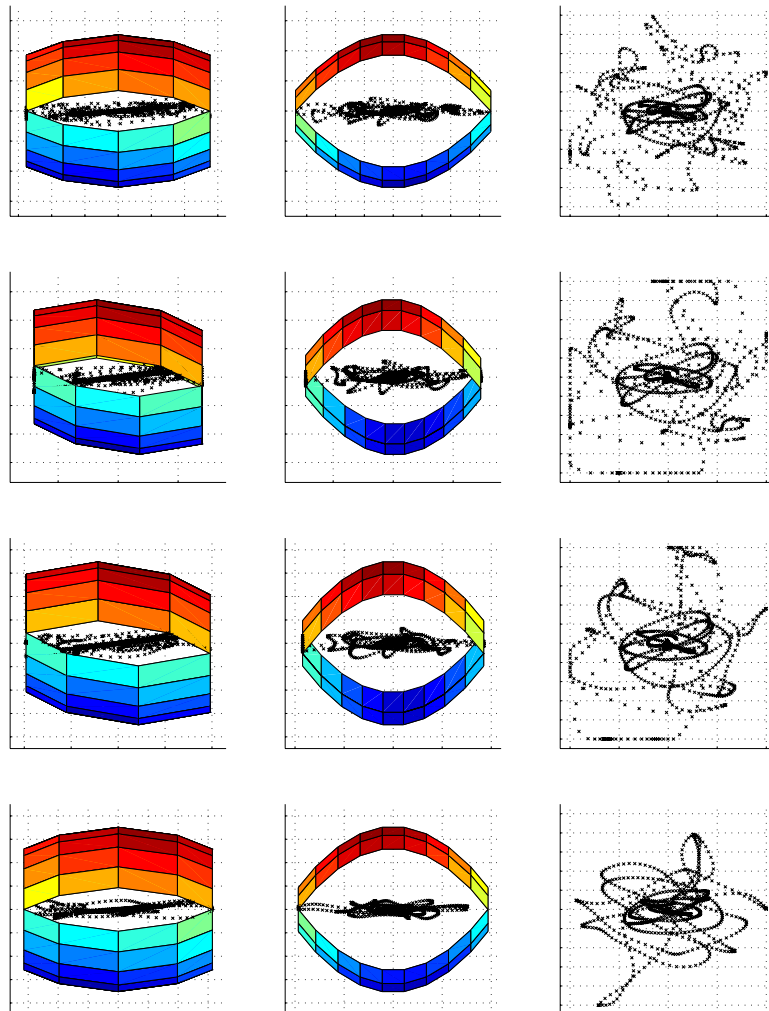
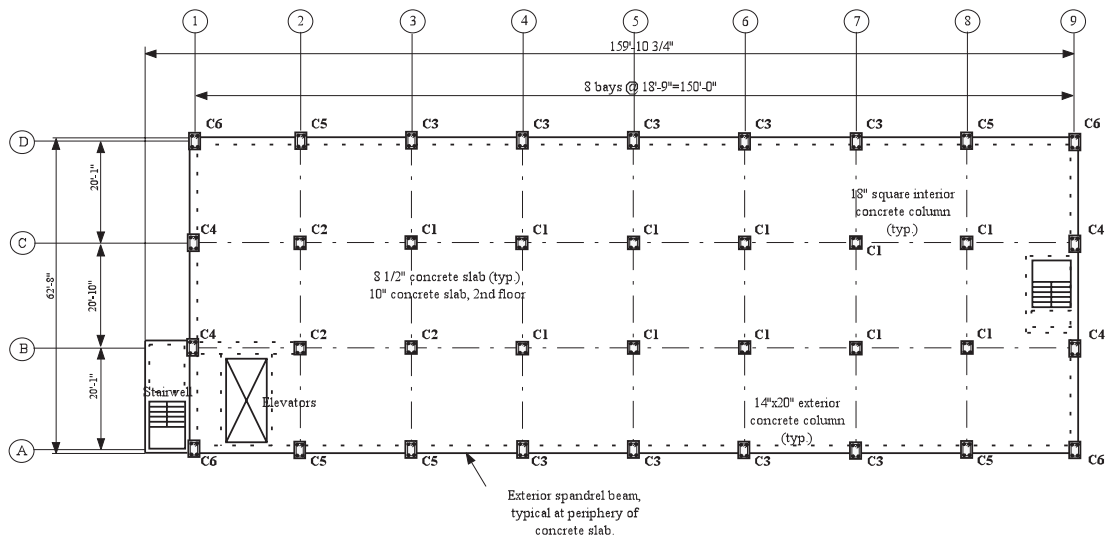

Figure 3 Inelastic response of a seven story R/C building using USST surface and the SEM model