

SEISMIC PROTECTION OF ITALY'S HISTORIC HERITAGE USING THE SEISMIC ISOLATION APPROACH

Alberto PARDUCCI¹

SUMMARY

This paper deals with the practical problems arising from the application of the Seismic Isolation techniques to the safeguard of historic buildings and cultural heritage. The discussion takes the opportunity of some important initiatives recently promoted by the Italian Government after the seismic "swarm" that struck central Italy in 1997 and 1998. These earthquakes damaged many ancient structures in the Umbria region, including some important artistic buildings and many typical construction of the historic environment. The specific effectiveness of the Base Isolation when it is applied to masonry structures of the ancient structures is then underlined. The results of some demonstrative designs are discussed to emphasise the high seismic performance that can be achieved in this field, taking into account the specific criteria that must be fulfilled in Italy to design the rehabilitation and the restoration works of the historic architecture.

INTRODUCTION

This paper deals with practical considerations about the use of the Seismic Isolation approach to safeguard the Italian historic heritage. Seismic isolation is a relatively new concept that is coming out of its pioneer period. Generally, it is applied using the Base Isolation and Energy Dissipation strategies. At the present time, the base isolation is becoming a construction system widely used for the seismic protection of many types of structures. Theoretical studies, numerical analyses and laboratory tests have clearly demonstrated the excellent performances that can be achieved through its application. Moreover, the high effectiveness of base isolation approach was clearly shown by the records of the real response of isolated buildings that have been struck by the severe earthquakes of Los Angeles, in California in 1994 [EERC, 1994] and Kobe, in Japan in 1995 [Kyoto University, 1995], [SSN, 1995].

Now, the effectiveness and versatility of seismic isolation open the way to new fields of applications that include the seismic protection of masonry structures [Parducci 1999]. Taking advantage of this potential, the purpose is to discuss how the seismic isolation approach can be suitably applied to improve the seismic capacity of the architectural heritage against the major seismic attacks. The peculiarity of this approach depends on the restraints imposed by the specific criteria that govern the preservation of such works [Parducci and Mezzi, 1992], [Garevski, (1995)]. Therefore, the related design procedures should be analysed to be harmonised to the requirements of the typical configurations and materials of the Italian heritage. At present some important initiatives, which include research and experimental applications, have been started in Italy to promote the use of new technique in this field.

Unfortunately, the base isolation approach cannot always be applied to retrofit the historic buildings. The possibility of its application mainly depends on the actual configuration of the existent ancient structures, especially when their construction has been progressively modified with the addition of irregular elements and superfetations. Moreover, the retrofitting works required by the application of the base isolation systems may be

¹ Department of Water and Structural Engineering, University of Perugia, Italy E-mail: parducci@unipg.it

very expensive. For instance, often the floors at ground level are irregularly connected over a large area and sometime they rest directly on the soil. Therefore, the application of a base isolation system requires the construction of a new floor and a new foundation.

On the other hand, when the base isolation approach can be suitably applied beneath the foundation level, it guarantees a seismic performance very effective. The appropriate isolating system can be directly related to the actual seismic capacity of the existing structure. So, no strengthening works of the structure are required above the isolating interface and the historic structure is not modified. In theory the seismic performance, depending on the natural period, can be designed to withstand any degree of seismic intensity. In practice, the design limitations derive from the lateral displacements that the structure can undergo during the seismic attacks and other lateral forces.

More than the technical problems, the use of the seismic isolation is severely limited by suspicion and mistrust due to the novelty of the system even in the field of new constructions. This attitude is obviously reflected in the sphere of cultural heritage [Parducci A., 1999]. Sometimes, a certain time is necessary to remove prejudice and to apply the results of the scientific research.

2. DEVELOPMENT OF THE SEISMIC ISOLATION IN ITALY

During the decade from 1983 to 1993 seismic isolation was widely used in Italy for the seismic protection of many bridges. More than 100 highway structures (new constructions and retrofitted existing structures) were equipped with a seismic isolation system. According to the performance of the typical bridge configurations, the ED approach was generally applied [Parducci and Mezzi, 1992], [Skinner, Robinson, McVerry, 1993]. Over the same period, only a few applications of the base isolation concerned structures other than bridges, like the residential and commercial buildings. Due to the restriction of road constructions, but also to the above-mentioned suspicious attitude, after 1993 the seismic isolation was virtually ignored in Italy.

Recently, a new interest in the use of the seismic isolation has been caused by the earthquake "swarm" that struck the Umbria and Marche regions in central Italy in 1997 and 1998. Thanks to the persevering action of the author of this paper the Government of the Umbria Region decided to finance the execution of a wide demonstrative project in order to promote the general use of seismic isolation in the field of the ordinary residential and commercial buildings.

On the other hand, the most serious consequences of these earthquakes are the severe damages caused to ancient and historic buildings, especially in the Umbria region. Umbria is a region in central Italy which is particularly rich in cultural and artistic assets. Some important historic buildings were damaged. Severe collapses involved the Gothic false-vaults of the Basilica of "San Francesco" in Assisi(1), which were painted by Cimabue in the 13th century. Besides this, equally serious damage was wrought to many minor ancient structures making up the rich historical environment of the region.

After these earthquakes, the problem of the seismic protection of the historic heritage was widely debated in Italy and new initiatives have been promoted. Among them, the most important is the "Parnaso" project, promoted by the Department for Architecture and the Environment together with the Department for Scientific Research. Driven by the renewed interest for the application of the seismic isolating techniques, this project includes the theme of the use of innovative techniques for the seismic protection of historic and monumental buildings(2).

(1) This Basilica is one of the most important artistic and historic monuments in Italy where San Francesco is buried. It contains a lot of frescoes of the most important painters of the 13th century (Giotto, Simone Martini, Cimabue, ...). Assisi is the town often used by the Pope for international meetings and celebrations.

(2) This is the "Parnaso" project. Together with prof. G. Croci, the author of this paper shall be entrusted with the scientific co-ordination of the "ProSEESM" theme, concerning the seismic protection of historic and monumental buildings.

3. SEISMIC PROTECTION OF CULTURAL HERITAGE IN ITALY

Cultural heritage is a wide concept that includes many different situations and problems. The wealth of the architectural heritage derives from the artistic values of emergent single monuments having a high intrinsic value, like the Basilica of "San Francesco", but it also derives from the characteristics of the whole of the historic environment. The latter is made up of the numerous buildings in ancient towns, small villages, and even of a number of single minor elements distributed throughout the territory, like monasteries, castles, country churches, farm-houses, etc., that define the historic environment. In addition to their intrinsic value, all these buildings have an additional compound importance that also improves the intrinsic worth of all the other single elements. Beyond the emergent monuments and the residential buildings of the historic towns, more than 300 minor ancient structures (churches, palaces, etc.) were seriously damaged by the recent earthquakes and more than 400 undergo minor cracks. Due to the poor seismic capacity of the ancient structures, the seismic risk of all these buildings is very high in all the historic Italian regions. In Umbria, beyond the emergent monuments and the residential buildings of the historic towns, more than 300 minor ancient structures (churches, palaces, etc.) were seriously damaged by the recent earthquakes and more than 400 undergo minor cracks. Therefore, all these structures must be protected against future earthquakes.

The large success of the seismic isolation suggests that its use is extended to the seismic protection of these ancient buildings and other assets belonging to the cultural heritage, provided that the works involved are consistent with their structural configurations. Nevertheless, more than by technical problems, the main requirement to perform this step is the harmonisation to the strong conditioning deriving from the philological criteria that in Italy govern the preservation of the cultural and historic work.

4. SIMPLE APPLICATIONS OF THE BASE ISOLATION TO PROTECT SINGLE OBJECTS

The base isolation is a simple way to reduce both the seismic stresses on the structural elements and the horizontal accelerations transmitted to the floors and to the other elements of the buildings. Since the latter performance is not expressly considered by the design codes, it is usually disregarded in the design practice. On the contrary, it should be considered as a primary aspect of the seismic design, because it avoids damages to the non-structural elements and to the objects inside the buildings. This performance paved the way toward the use of the seismic isolation to protect the buildings containing high-cost equipment (for example, computer centres). Likewise, seismic isolation can be applied to reduce the seismic accelerations of the buildings containing artistic or historical works. Obviously, the simplest solution consists in the direct isolation of each object inside the museums.

This simple application was used in Italy to protect some ancient statues, like the two famous bronzes of Riace and the big bronze of the "Germanico" in Perugia. In these cases, the specific problem derives from the natural frequencies of the floor on which the statue is located and the interference with the oscillations of the isolated system. The isolating system of the "Germanico" was designed to protect the delicate metallic structure that had been set up to reassemble the heavy fragments of this statue that is more than two meters high. The isolating basement consists of three steel layers separated by soft-compound high-damping rubber bearings⁽³⁾. The natural period of the isolated system is about 2.4 seconds. It is located on the floor of an ancient masonry building having high natural frequencies that do not interfere with the lateral oscillations of the statue.

5. SPECIFIC PROBLEMS FOR THE PROTECTION OF THE ARCHITECTURAL HERITAGE

The preservation of ancient buildings (churches, palaces and so on) having a cultural or historic value is a very complex problem. The difficulties do not depend on the design of the technical solutions, but on the specific requirements that govern this specific subject in Italy. In accordance with the philological criterion, very restricted requirements must be fulfilled to design the rehabilitation works of historic buildings. This trend derives from a strong popular willingness to wish to preserve our historical traditions. Mainly, it is strongly recommended that the rehabilitation works be "non-invasive" and "reversible". The former limitation does not allow, for example, that the building could be strengthened by the use of additional structural elements. Both the requirements limit the extensive use of new materials to strengthen the existing structural elements. In any case, the existing architectural morphology, the structural configuration and even the original materials should be preserved and they cannot undergo significant modifications.

⁽³⁾ The isolating system and the high-damping rubber bearings were manufactured by "Alga". The isolating system was mobilised by the earthquakes of March 14, 1998.

These requirements can be fulfilled when the buildings are located outside of a seismic zone and the goal is to eliminate the degradation effects and restore the original situation. On the other hand, the same requirements can really puzzle a structural designer when he is asked to transform a non purposely designed structural configuration into an effective anti-seismic system.

The elementary scheme of the energy-based approach shown in Figure 1 is the best way to put the problem into perspective, taking into account the specific requirements of historic buildings. The classical approach to resist the strongest earthquakes, usually applied to ordinary buildings, is based on the ductility capacity of the structure. Since generally the elastic energy is largely inadequate to adsorb all the input energy, the structure will have to be provided with a large hysteretic capacity of plastic deformations, so that a large amount of energy can be dissipated.

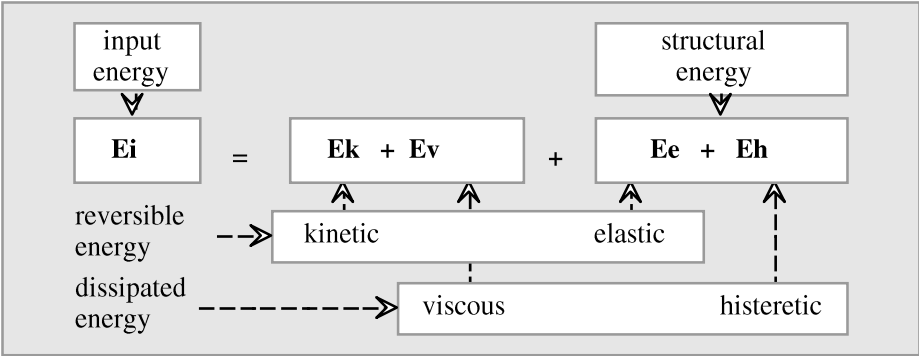

Fig. 1 - The main terms of a simplified energy-based approach.

The paradoxical aspect of this approach is that mitigation of the seismic damage of a structure is based on the (controlled) damages of the same structure. Although this criterion can be accepted from the economic point of view, it is clearly in contrast with the aims of the rehabilitation criteria applied to the buildings having historical and artistic value. The contrast is more evident when the structural walls of the building are also the original support of frescoes or mural paintings, where even the cracks of the painted surfaces are considered an irreparable damage. On the other hand, the way of the structural strengthening cannot be cover, because the rehabilitation works up to an appropriate safety level are certainly too much invasive. Furthermore, the strengthening works make the structures more stiff and the transmitted accelerations are not reduced (on the contrary, they can be increased). In any case, this is in contrast with the requirements of the philological approach.

Two further ways can be devised to solve this problem. One way is to insert special energy dissipating elements that are free to slide over each other into the structure, or between parts of it. Since the permanent displacements that characterise plastic deformations are not admitted, classical elasto-plastic devices cannot be used. Important studies are being carried out on the application of prestressing effects obtained by the use of the SMA (shape-memory-alloys) [Waymann, 1993], taking advantage of their "super-elasticity" behaviour [SSN, 1995-99]. The other solution is the reduction of stresses and accelerations through the application of the base isolation approach, that is the subject of this paper. The target becomes a large reduction of the seismic input. When it can be applied, the latter approach is the only way that can totally avoid the need for invasive works above the isolating interface.

6. SUITABLY PERFORMANCES FOR MASONRY STRUCTURES

The base isolation approach guarantees very high performances when it is applied to protect masonry structures [Parducci, 1999]. This is due to the stiffness of the masonry structural elements that makes the base isolation very effective. Therefore, the base isolation appears as an effective technique to protect the historic and monumental buildings which are made by masonry structures.

If we consider the typical performances of the base isolation, we know that a strong improvement of the seismic capacity is obtained when the following parameters reach high values:

- the fundamental period of the base isolated structure,

- the ratio between the reference period of the base-isolated structure(4) and the fundamental period of the same fixed-base structure.

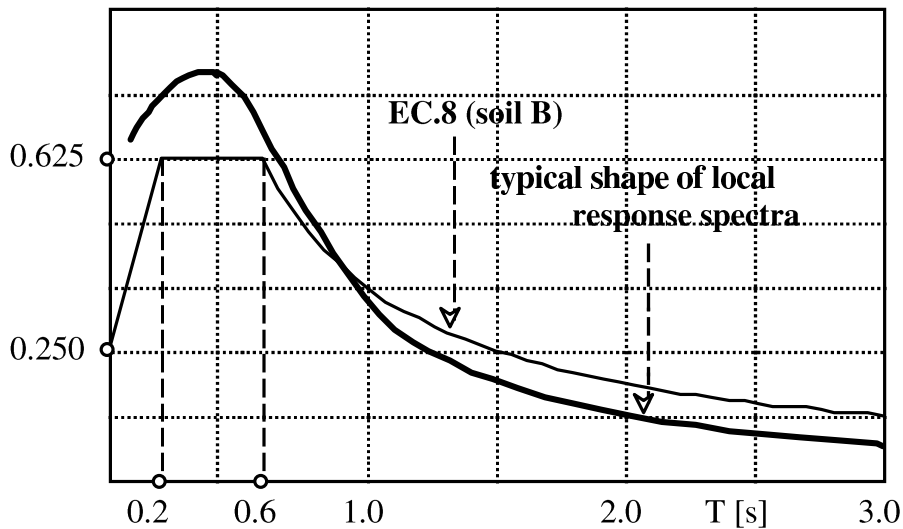

Fig. 2 - Typical shape of the response spectra in the Umbria region compared with the EC.8 design spectrum (PGA = 0.25g, soil B).

The former requirement should reach at least two seconds to maintain the structure certainly out of the range of the typical frequencies of the seismic inputs. In connection with this aspect, the base isolation can be more effective than the design expectation in many seismic zones. This occurs in the Umbria region(5), where the earthquake focuses are not very deep and the seismic energy is mainly transmitted in the field of high frequencies (Fig. 2). The latter parameter should be greater than three, to achieve a real de-coupling effect of the motion of the structure from that of the soil. In addition, it is appropriate that the structural materials of the buildings above the isolating interface do not undergo significant plastic deformations.

We also know that the favourable seismic response of the isolated structures depends on the following performances, complying with the previous requirements:

- The first lateral mode is almost shaped like a rigid body which moves above the isolating interface. The participation factor of this mode, that practically does not stress the structure, is very high, greater than 90%.
- The participation factors of the higher modes, on which the stresses of the structure mainly depend, are very small. Therefore, they are not very effective in the seismic response.
- The seismic accelerations transmitted through the first mode, compared with those of the non-isolated structure, are considerably reduced, mainly at the higher levels.

This is a known behaviour that has been considered to underline that the base isolation increases the relative importance of the lateral stiffness unlike to the mechanical resistance concept. Therefore, the use of the base isolation modifies some criteria that define the strategies of the seismic design. Due to the increased importance of the stiffness compared with the resistance concept, the base isolation can be regarded as an effective technique to be suitably applied to simple masonry structures, making them safe enough against severe seismic attacks. Although the shear resistance and ductility of the masonry structures are not very high, the brick panels have

(4) The reference period of an isolated base structure is defined as the natural period of the structure, supposing that it rigidly moves upon the flexible isolating devices.

(5) The design spectrum of Eurocode 8 has a generalised shape to cover all the seismic situations, but the actual shapes related to specific zones may present some differences. Many estimates made in the Umbria region show that in general EC.8 could be considered too safe for the low frequencies and relatively unsafe for the high frequencies.

high shear stiffness, as the base isolation requires. Then, the base isolation can rehabilitate the use of masonry structures in seismic areas, so that it is really an effective technique to be applied to the historic buildings, which were actually made with masonry structures.

7. RETROFITTING DESIGN PROCEDURE WHEN BASE ISOLATION IS APPLIED

The design of a base isolation system for the retrofitting of an existing structure can be performed using a reverse procedure. Starting from the actual seismic resistance of the structure, the required natural period to maintain it in the elastic range can be defined. To illustrate an example, Fig. 3 shows the design spectrum of Eurocode 8 (Sa acceleration spectrum versus Sd displacement spectrum) for a seismic intensity of a peak ground acceleration $PGA = 0.25g$ (the general value to be used in Umbria), a medium stiff soil (soil B) and 5% of equivalent damping. Due to the use of the HDRB (High Damping Rubber Bearings), the acceleration spectrum is reduced in the range of low frequencies to take into account the damping effect of the dissipating devices (about 10%) on the isolated first mode.

Let us consider the average characteristics of masonry buildings (gross weight, density, arrangement and distribution of bearing walls, etc.). The natural period of the fixed-base structure is certainly lower than 0.6 seconds. Assuming that the estimated structural capacity of the existing structure corresponds to the design acceleration $Sa = 0.125g$, the ductility demand is $\mu = 5$ or greater. This value is not consistent with the capacity of the masonry structure. If a base isolation system that leads to the natural period to $T = 2.3$ seconds, the structure becomes totally safe without plastic deformations under the same design earthquake. The displacement of 168 mm of the bearing devices is required. It is consistent with the characteristics of the multi-layer rubber bearings (for example, $\varnothing = 300\div400$ mm of a soft rubber compound bearings) located under the ground floor at an average distance of about 2.0 or 2.5 meters.

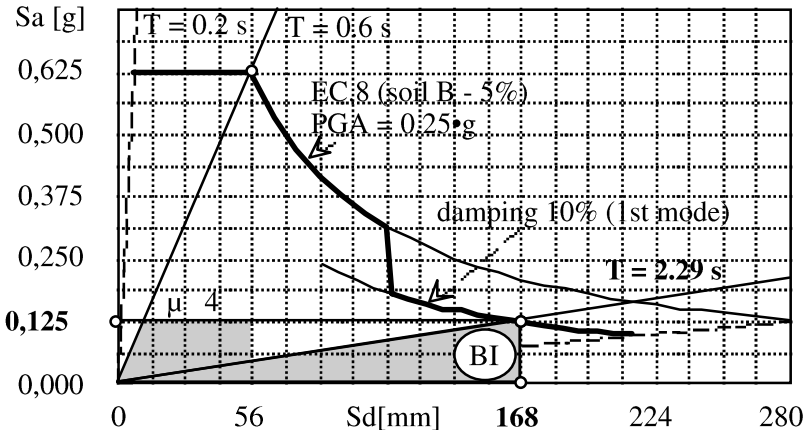

Fig. 3 - EC.8 design acceleration spectrum versus displacement spectrum.

From a general point of view, these results demonstrate the feasibility of the use of base isolation to achieve a very high protection level of the masonry structures. Therefore, they can be advantageously applied to safeguard the historic buildings. The actual configurations of the design spectra previously shown for the regions of central Italy (Fig. 2) also guarantee a real safety level even higher than that corresponding to the application of the EC.8 spectrum.

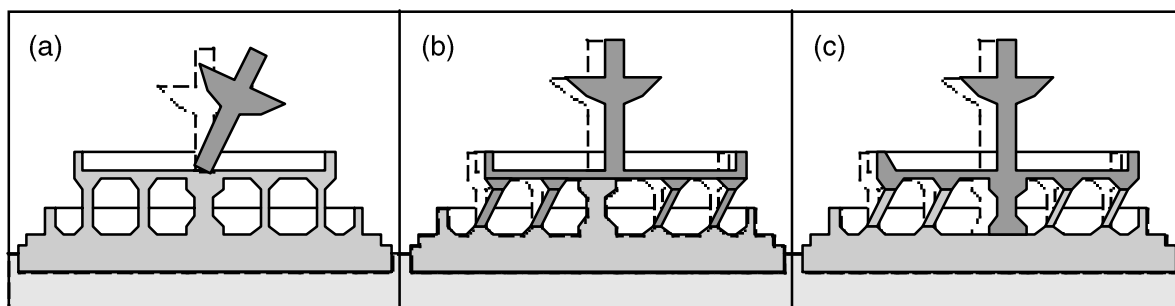

Fig. 4 - Three potential collapse mechanism of the "Fontana Maggiore" in Perugia⁽⁶⁾.

The design of a base isolation system that ensures the total seismic protection of an existing building can be defined by taking into account the shear resistance of the actual structure. This is the most interesting aspect when this technique can be applied, because in this case the strengthening works of the structures above the isolating interface can be avoided or at least strongly reduced. In fact, the isolating devices can be inserted under the foundation level (Fig. 5.b).

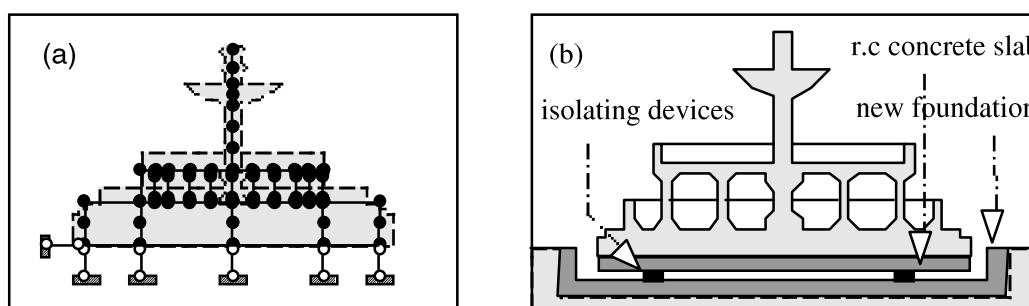

Fig. 5 - Scheme of the numerical model and lay-out of the base isolation system.

To illustrate an example of this criterion, the design procedure was applied considering the "Fontana Maggiore" in Perugia. The main collapse mechanisms are shown in Figure 4. Their shear resistance was estimated. Then, a set of artificial accelerograms consistent with the estimate design spectrum corresponding to a return period of about 1000 years were applied to the numerical model (Fig. 5.a) to calculate the required natural period of the isolating system (Fig. 5.b). The performance that can be achieved with a natural period of 2.3 seconds corresponds to the situation shown in the Figure 3.

8. CONCLUSIONS

When its application is consistent with the structural configuration of a historic building, the base isolation is a very effective way to protect cultural heritage. The possibility of reducing and even avoiding strengthening works of the structures above the isolation interface is the most attractive performance from the point of view of the philological criterion that rules the rehabilitation works.

⁽⁶⁾ This is the most representative monument of the town. It was built in the 13th century, at the beginning of the Italian Renaissance. Beautiful bas-reliefs made by Nicola and Giovanni Pisano adorn the two round basins. Historic sources report that the upper bronze sculpture was actually damaged by an earthquake in 1438.

REFERENCES

- EERC (1994) Earthquake Engineering Research Center: "Preliminary Report on the Seismological and Engineering Aspects of the January 17, 1994 Northridge Earthquake" - Report No. UCB/EERC-94/01 - University of California - Berkeley (California) - January 1994.
- Garevski M. (1995): "Earthquake Hazard Reduction of Historical Buildings using Seismic Isolation" - Report No. UCB/EERC- 95/04 - University of California - June 1995.
- Kyoto University (1995): "Preliminary Report on the Great Hanshin Earthquake, Jan. 17 1995" - Disaster Prevention Research Institute - Kyoto University - Special Issue - February 1995.
- Mezzi M. and Parducci A. (1998): "Base Isolation in Retrofitting of Historical Buildings" Workshop on Seismic Performance of Monuments - Lisboa (Portugal) - November 1998.
- Parducci A. (1999): "Seismic Isolation: Why, Where, When" - Post-SmiRT Conference Seminar - Cheju (Korea) - August 1999.
- Parducci A., Mezzi M. (1992): "Seismic Isolation of Bridges in Italy" - Bulletin of the New Zealand National Society for Earthquake engineering - Vol. 25, No.3 - September 1992.
- Skinner R. I., Robinson W. H., McVerry G. H. (1993) - "An Introduction to seismic isolation " - DSIR Physical Sciences, Wellington (New Zealand) - John Wiley & Sons, 1993.
- SSN (1995) Dip.to per i Servizi Tecnici Nazionali: "Il Terremoto di Kobe del 17 Gennaio 1995" - Rapporto del Servizio Sismico Nazionale (in Italian) - Roma, March 1995.
- SSN (1995-99) Servizio Sismico Nazionale: "Manside Project" - Brite Euram Programme of the European Commissions - BRPR-CT95-0031 - 1995-99.
- Waymann C. M. (1993): "Shape Memory Alloys" - MRS Bulletin - MRS Meeting Department - Pittsburgh - April 1993.