

PSEUDO-DYNAMIC TEST ON REINFORCED CONCRETE FRAME RETROFITTED WITH DAMPER

Hiromi ADACHI¹, Keiji KITAJIMA², Hideaki AGETA³ And Mitsukazu NAKANISHI⁴

SUMMARY

The purpose of this study is to experimentally verify the feasibility of one of the new seismic retrofit systems, namely the application of dampers. A reinforced concrete frame with inadequate shear strength in its columns was retrofitted with members composed of friction dampers and steel braces. The performance of this retrofit system was confirmed by a pseudo-dynamic test. In addition, it was shown that the test results can be reproduced in elasto-plastic response analysis with a parallel two-spring SDOF(single-degree-of-freedom) system, i.e. a model of the main structure and the damper-brace.

INTRODUCTION

Incorporating additional energy absorbing devices (i.e. dampers) into structures has been proposed as a means of improving seismic performance of existing buildings in recent years[1]. The practical application of a retrofit method that optimizes this response control technology (“damper retrofitting method”) is being much hoped for, as it allows retrofit work to be carried out without interrupting the ordinary function of buildings. Unfortunately, only a few researches have ever been carried out on the effect of the damper retrofitting method on reinforced concrete (hereinafter called “R/C”) structures, a structural type probably most in need of seismic retrofits. Moreover, most of such researches are analytical, and very few experimental investigations have been conducted so far.

The authors have taken analytical approaches to demonstrate the feasibility of the damper retrofitting method by carrying out seismic response analyses on how the seismic performance of a structure is enhanced by incorporating dampers with energy absorbing capability into R/C structures [2] [3]. The present study, by contrast, is aimed to prove the validity of this method experimentally. A two-span two-story reinforced concrete frame where the shear failure of the columns was the prevalent failure was retrofitted with members composed of friction dampers and steel braces (hereinafter called “damper-brace devices”). The seismic performance of this retrofit system against input ground motions equivalent to Level 2 was then confirmed in a pseudo-dynamic test. To study the seismic performance in depth, the story shear force measured in the test was theoretically divided into a shear force shared by the main structure and that shared by the damper-brace. Furthermore, it was shown that the test results were able to be reproduced in elasto-plastic response analysis using a representation of the resistance mechanism, namely the parallel two-spring SDOF (single-degree-of-freedom) system.

¹ College of Science and Technology, Nihon University, Tokyo, Japan. Email: adachi@ocean.cst.nihon-u.ac.jp

² Technical Research Center, Aoki Corporation, Ibaraki, Japan. Email: KeijiKitajima@aoki.co.jp

³ Technical Research Center, Aoki Corporation, Ibaraki, Japan. Email: HideakiAgeta@aoki.co.jp

⁴ College of Science and Technology, Nihon University, Tokyo, Japan. Email: sanwa@ocean.cst.nihon-u.ac.jp

OUTLINE OF TEST

Test Specimens

The structure assumed in designing the test specimens was a short R/C building (four-storied) which complied with the old seismic code but not the new one. Two main structures were 1/3-scale models of two-story two-span R/C frames whose columns and beam-to-column joints had inadequate shear strengths. They had the same shape and reinforcement specifications, but while one of them was unretrofitted, the other was retrofitted with damper-braces. The configurations of the specimens are shown in Figure 1, and lists of cross sections and material properties are given in Tables 1 and 2 respectively.

Table 1: List of cross sections

Columns	Beams (2nd floor)	Beams (1st □ 3rd floors)
		
$\square \times \square = 200 \times 220 \text{mm}$	$\square \times \square = 160 \times 290 \text{mm}$	$\square \times \square = 200 \times 400 \text{mm}$
14-D10 $P_g = 2.27\%$	7-D10 $P_t = 1.20\%$	6-D13 $P_t = 1.05\%$
$\phi 4 - @ 150$ $P_w = 0.08\%$	$\phi 4 - @ 80$ $P_w = 0.20\%$	D6-@100 $P_w = 0.32\%$

Table 2: Material properties

(a) Concrete

Members	Concrete age [day]	Compressive strength [MPa]	Splitting tensile strength [MPa]
Beams(3rd floor)	59	23.9	2.6
Beams and columns (2nd floor)	69	18.2	1.8
Beams(1st floor)	87	26.7	2.5

(b) Reinforcing bars

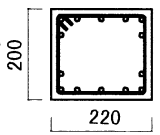
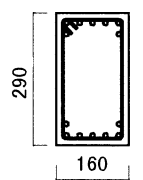
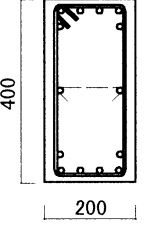
Members	Yield strength [MPa]	Tensile strength [MPa]	Young's modulus [GPa]
Main reinforcement in beams (1st 3rd floors)(D13)	316	461	187
Stirrups in beams (1st □ 3rd floors)(D6)	394	603	224
Main reinforcement in beams and columns (2nd floor)(D10)	342	503	184
Stirrups in beams and hoop reinforcement in columns (1st □ 3rd floors)($\phi 4$)	557	617	213

The retrofitted specimen was equipped with the damper-braces installed diagonally to form V-shapes. Figures 2, 3 and 4 show the configuration of the friction damper used, the result of individual performance testing on it, and the detail of the connection between the damper-brace and main structure, respectively. The design of the damper-brace (i.e. the friction load of the damper, or the damper strength, and the cross section of steel braces) was determined in a way that would keep the response displacement of the columns below the shear failure point, based on a preliminary response analysis where the damper strength and the braces' axial stiffness were set as parameters. The devices were installed in the following procedure: transversal holes were first made, through which steel bars for prestressing were inserted at the end and center of beams; grout was then injected between the distribution plates at both ends and beams; and the devices were clamped with the inserted steel bars after the strength of the grout had developed. Based on the results of the test on the connection [4], the clamping force and the size of the distribution plates were determined in a way which would make the grout-beam friction force and the bearing stress intensity in the grout be adjusted at 1.0 and 2.0 MPa, respectively.

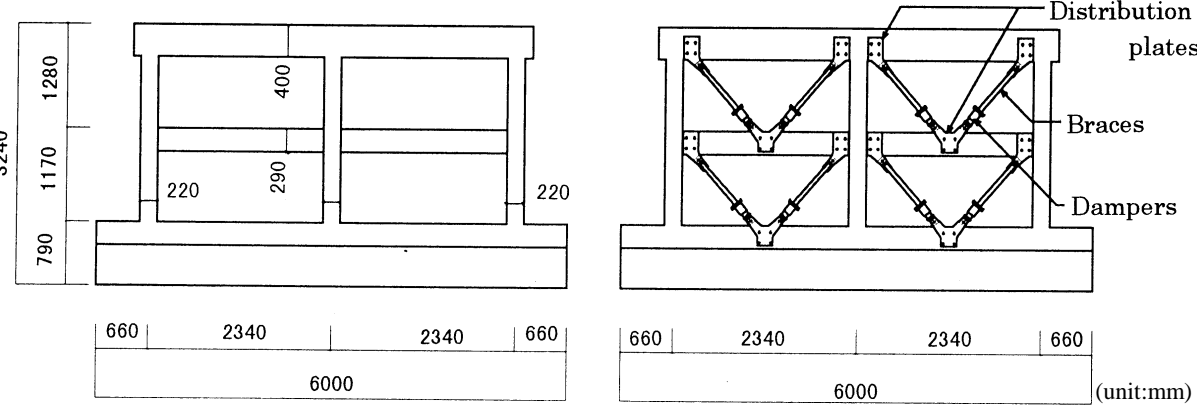

(a) Unretrofitted test specimen (b) Retrofitted test specimen
Figure 1: Configurations of the test specimens

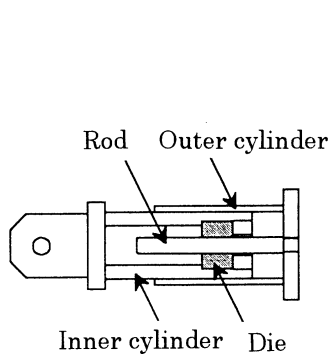

Figure 2: Configurations of the damper

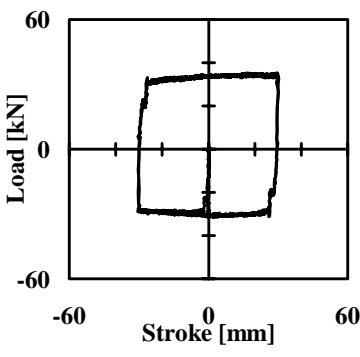

Figure 3: Results of performance testing on the damper

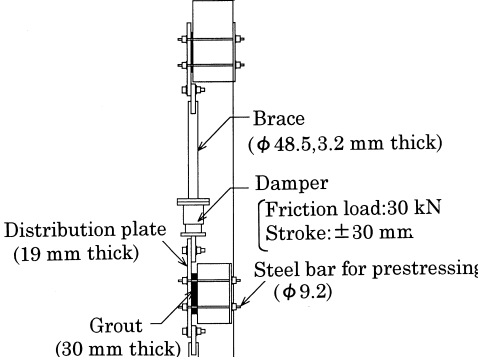

Figure 4: Detail of the connection

Test Procedure

Procedure of pseudo-dynamic testing

The pseudo-dynamic testing, from which the response values of structure under earthquake motion are directly derived, is a more vigorous and clear method of confirming the effect of the damper retrofitting method than the positive and negative alternating loading method which assesses the strength and deformability of a structure. The test specimens were represented by the SDOF system, to which response displacements were applied while solving vibration equations by the Newmark explicit method. The pseudo-dynamic testing was carried out after confirming the validity of the test system in an elastic response test on a simulated steel specimen. Adopted here was a method incorporating a technique to calibrate errors produced by various causes inherent in the test system [5]. The input ground motion was produced by normalizing the maximum acceleration of the N-S

component of El Centro(1940), and set at 5.11 m/sec^2 which was equivalent to the Level-2 ground motion for Building Center of Japan. The time-base decreased according to the principle of similarity, the major ground motions were inputted for 4.0 seconds, and the time interval was set at 0.012 seconds. The viscous damping factor was 3 %, and the weight of the structure 441 kN.

Loading Method

The loading equipment is shown in Figure 5. Two actuators were used: one for vertical loading and another for horizontal loading. Axial forces were applied through axial force-bearing beams in the upper part of the specimen in a way which would distribute an equal axial force to each column (147kN). The out-of-plane deformation of the specimens was restricted with pantographs installed on the axial force-bearing beams. The upper part of the actuator for vertical loading had roller bearings to obey the horizontal deformation of the specimens.

Measurement Procedure

The restoring forces of the specimens to be adopted in response analysis were measured with the load cell at the tip of the actuators, and the horizontal displacement of the specimens to be controlled as response displacement was measured with the digital displacement gauge on the top of the central column. Other measurement items included: the horizontal and vertical displacements of each joint, the out-of-plane deformation of the specimens, the strain of the main reinforcement at the end of each column and beam, the main reinforcement at the center of the beam to which distribution plates were applied, and the strain of the hoop reinforcement in columns and beam-to-column joints. In addition, strain gauges were attached to the braces to obtain axial forces working on the damper-brace using a calibration factor obtained in advance. Slippage and lifting of the distribution plates were measured with a bi-axial crack displacement gauge.

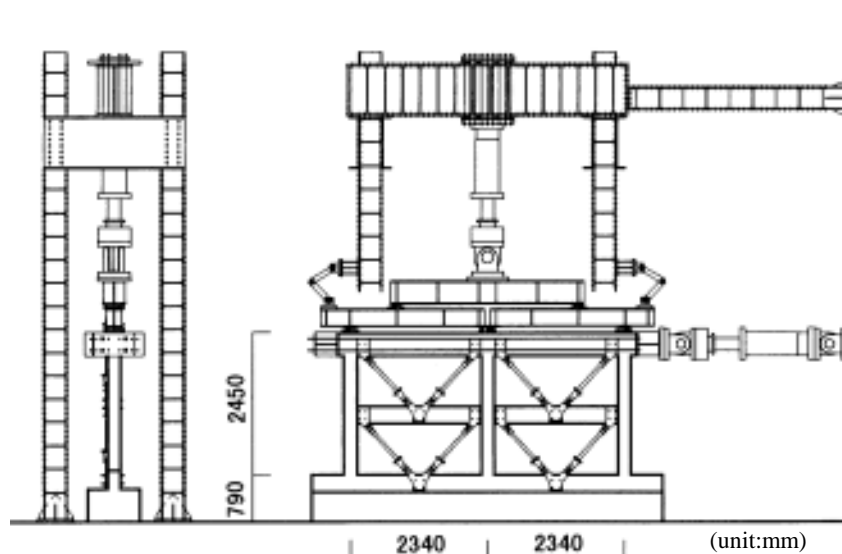

Figure 5: Loading equipment

TEST RESULTS

Positive and Negative Alternating Loading Test on The Unretrofitted Test Specimen

To study the basic properties of the unretrofitted specimen, a positive and negative alternating loading test was performed on it before carrying out the pseudo-dynamic test on the retrofitted specimen. The specimen underwent one cycle each for overall deformation angles $R=\pm 0.25\%$ and $\pm 0.33\%$ and two cycles each for $\pm 0.30\%$, $\pm 0.67\%$ and $\pm 1.00\%$. Afterwards at $R=\pm 1.14\%$, the top of the 2nd floor column went into shear failure with the strength deteriorated. The maximum strength 179 kN was observed at $R=\pm 1.00\%$. The final failure state of the unretrofitted specimen and the horizontal load-displacement relationship are in Figures 6 and 7, respectively.

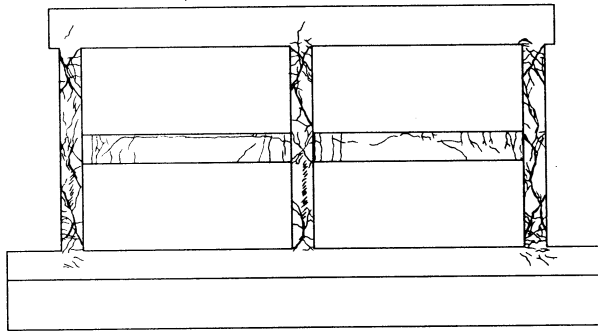

Figure 6: Final failure state of the unretrofitted test specimen

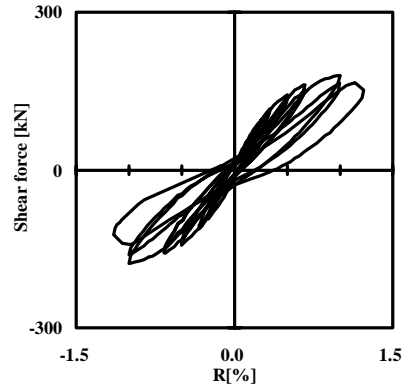

Figure 7: Load-displacement relationship of the unretrofitted test specimen

Pseudo-Dynamic Test on The Retrofitted Test Specimen

Figure 8 shows the time history of the response deformation angle obtained in the pseudo-dynamic test on the retrofitted specimen. The response hysteresis curves and the final failure state are shown in Figures 9 and 10, respectively. The specimen experienced the maximum response deformation angle $R = -0.63\%$ at 0.84 seconds after inputting a ground motion equivalent to Level 2, and showed deformation angles of 0.3 to 0.4% between 2.0 and 3.0 seconds after inputting the ground motion. On reaching the maximum response values, the columns and beam-to-column joints induced shear cracks, and the main reinforcement at the top of the 2nd floor columns reached the yield strain stage on the tensile side. However, no reductions in the horizontal bearing capacity and the axial holding capacity were observed. The response hysteresis curves (Fig.9) show bi-linear convexity, demonstrating that the response hysteresis of the specimen greatly depended on the hysteresis characteristics of the damper. Presumably, the performance of the damper was fully displayed, because no deformation such as slippage or lifting was observed at the connection between the damper-brace and main structure.

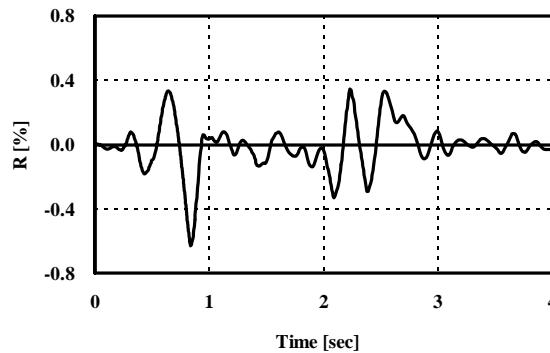

Figure 8: Time history of response deformation angle

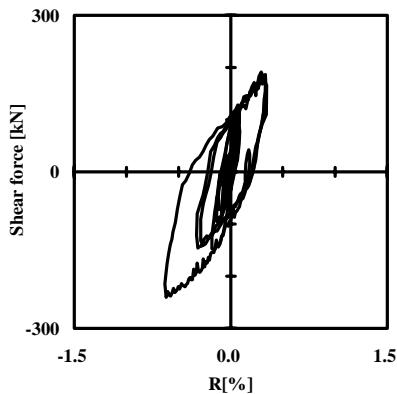

Figure 9: Response hysteresis curves

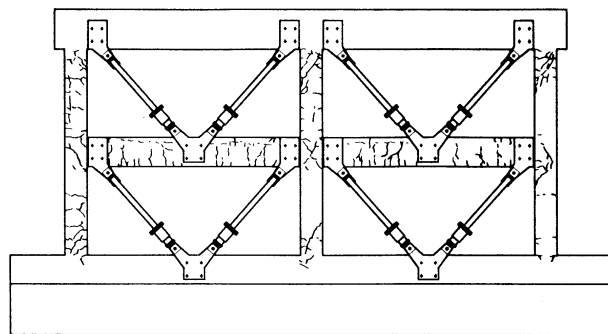

Figure 10: Final failure state of the retrofitted test specimen

INVESTIGATION OF THE TEST RESULTS AND DISCUSSIONS

Isolation of The Shear Force Shared by The Damper and Energy Consumption

To carry out further investigation of the effect of the damper retrofitting method confirmed in the test, the story shear force of the retrofitted specimen was theoretically divided into a shear force shared by the damper and that shared by the main structure. In this chapter, the hysteresis curves and the hysteretic energy consumption of each shear force are compared. Note that the term “main structure” refers to an R/C frame consisting of columns and beams here. Figure 11 shows the hysteresis curves of the shear force shared by the damper and those of the shear force shared by the main structure. The shear force shared by the damper is the sum of the horizontal components of the axial forces in the damper-braces installed on two floors. The shear force shared by the main structure is the discrepancy between the story shear force and the shear force shared by the damper. The hysteresis curves of the shear force shared by the damper (Fig.11(a)) show bi-linear convexity similar to the result of the test on the damper alone. The maximum value also corresponds well with the sum of the horizontal components of the result of the test on the damper alone. This confirms that the performance of the damper alone represents the effectiveness of the whole retrofit system. The hysteresis curves of the shear force shared by the main structure correspond well with those of the unretrofitted specimen (chain lines in Fig.11(b)). This reveals that the hysteresis curves of the retrofitted specimen are the sum of those of the main structure and the damper.

Figure 12 shows the time histories of the hysteretic energy consumptions of the damper and the main structure, which were obtained by integrating along the hysteresis curves. The energy consumption by the damper accounts for a large percentage of the entire hysteretic energy consumption, which proves that the lack of the energy-absorbing capacity of the main structure is supplemented by the damper. At the end of the test, the percentage of the energy consumption by the damper (7.31 kN·m) to the entire hysteretic energy consumption (8.37 kN·m) was about 87%.

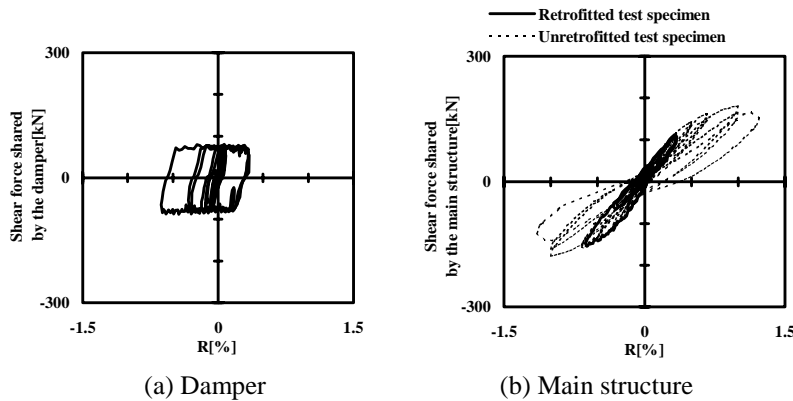

Figure 11: Hysteresis curves of the damper and the main structure

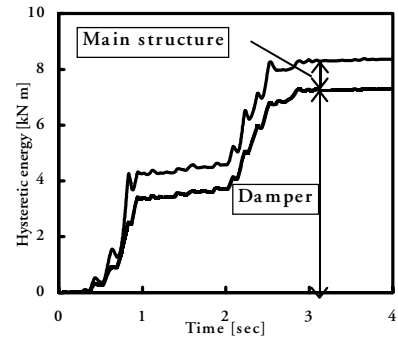

Figure 12: Hysteretic energy consumption

Comparison between The Results of The Test and Those of The Analysis

To prove that the test results can be reproduced in analysis, the results of the test and analysis on the retrofitted specimen are examined for comparison here, on the assumption that the resistance mechanism of the retrofitted specimen can be represented by the resistance mechanisms of the damper and main structure represented by shear springs connected parallel to each other. The skeleton curve obtained in the test on the unretrofitted specimen was represented by the tri-linear model, and the hysteresis characteristics of the Takeda model (unloading stiffness degradation parameter: 0.4) were employed for the shear springs of the main structure. The shear springs of the damper were represented by the bi-linear model, and their initial stiffness and maximum strength were derived from the hysteresis curves of the damper (Fig.11(a)). The specifications for the analytical models are in Table 3, and those for the response analysis were designed to match those employed in the test. Likewise, the Newmark explicit method was employed with the time interval of 0.012 seconds.

Table 3: Specifications of the analytical models

	Main structure	Damper
Analytical model used	Takeda model	Bi-linear model
Load on the 1st break point[kN]	115.6	84.3
Load on the 2nd break point[kN]	178.4	-----
Initial stiffness[kN/mm]	15.0	31.7
Second stiffness [kN/mm]	6.3	0.001
Third stiffness□ [kN/mm]	0.002	-----
Unloading stiffness degradation parameter	0.4	-----

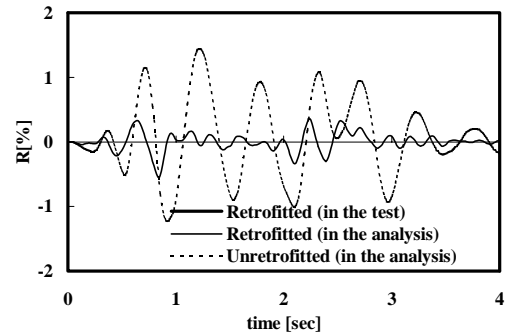

Figure 13: Comparison of the time histories of response deformation angle

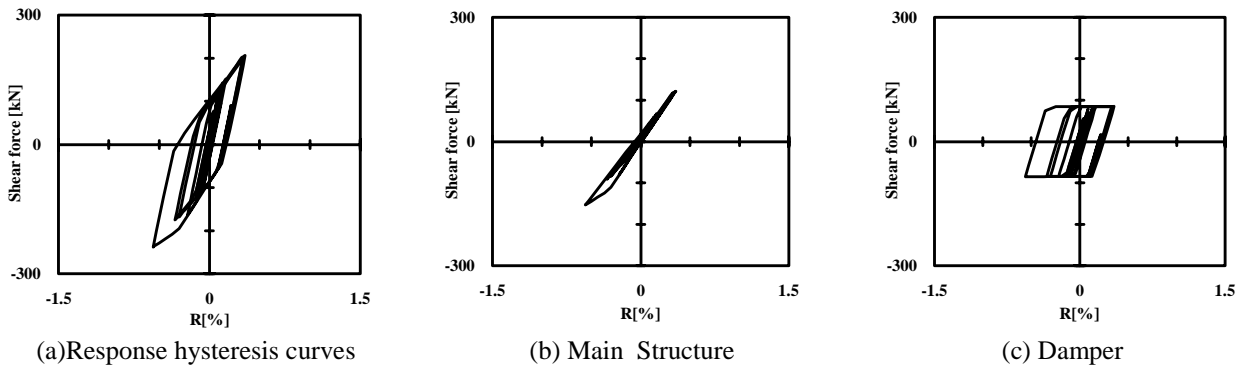

Figure 14: Response hysteresis curves and the hysteresis curves of the damper and main structure

The time histories of the response displacements obtained in the analysis are compared with the test results in Figure 13. The response hysteresis curves and the hysteresis curves of the damper and main structure are shown in Figure 14. It is clearly shown in Figure 13 that the actual response characteristics of the retrofitted specimen were accurately reproduced in the analysis. The results of the response analysis on the main structure alone are also plotted in Figure 13 for reference.

Figure 15 shows the equivalent viscous damping factors obtained by applying positive and negative alternating steady displacement amplitudes to the analytical models, as in the case of the unretrofitted specimen. Correlation was observed between the results of analysis on the SDOF system of the main structure and the results of tests on the unretrofitted specimen. Also, the results of analysis on the parallel two-spring SDOF system corresponded well with the results of tests on the retrofitted specimen. Note that the results of tests on the retrofitted specimen refer to the hysteretic area of a half cycle, that is from the point at which loading shifts from positive (negative) to negative (positive) to the point at which it shifts from negative (positive) to positive (negative). It is demonstrated in the figure that the damper's energy consumption enhanced the seismic performance of the structure, because although the equivalent viscous damping factors of the unretrofitted specimen were only between 5 and 14%, those of the retrofitted specimen were between 15 and 27%. This effect of the damper was also manifested in the analysis clearly.

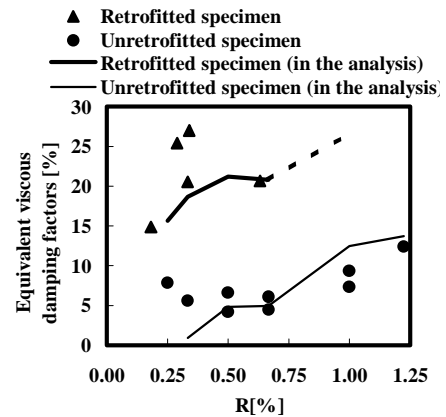

Figure 15: Equivalent viscous damping factors

CONCLUSIONS

The following insights were gained through the pseudo-dynamic test on a specimen retrofitted with damper:

1. When a seismically-vulnerable R/C frame with inadequate shear strength in its columns is retrofitted with dampers, its response displacements can be reduced to the level at which columns withstand an input ground motion equivalent to Level 2.
2. The test results showed that the energy consumption of the damper accounted for about 87% of the total hysteretic energy consumption of the structure. This means that the inadequate energy absorbing capability of the main structure is supplemented by the damper.
3. The resistance mechanism of the specimen retrofitted with dampers demonstrated by the test can be reproduced in response analysis on the parallel two-spring SDOF system of the damper and main structure.
4. Comparison between the equivalent viscous damping factor of an unretrofitted specimen and that of a retrofitted specimen proved that the damper retrofitting method improves the seismic performance of a structure.

ACKNOWLEDGMENTS

This study is part of a joint research by Nihon University and Aoki Corporation entitled "Study of Seismic Retrofit Technology for Damage Mitigation". The authors would like to express their thanks to the people who are engaged in the research. The test in the present research was carried out as part of the activities of "Experimental Study Committee for Development of New Seismic Strengthening Methods" (Chairman: Prof. Masaya Hirosawa, Kogakuin University) established by the Japan Association for Building Research Promotion. A great deal of assistance was received from Prof. Hirosawa, Mr. Masaaki Matsui (Sho-Bond Corporation) and all those involved in the committee. The pseudo-dynamic test was carried out as part of a research entitled "Research into Strength and Deformability of Reinforced Concrete Members"(Head Investigator: Hiromi Adachi), which is covered by a FY1996 grant from the Ministry of Education for scientific and technical research (comprehensive research B2).

REFERENCES

1. BMMC(1997), "Re (Building Maintenance Management : Seismic Retrofit using Base Isolators or Damping Devices)," *Journal of Building Maintenance & Management Center, No.102 and 104* , (in Japanese)
 2. Hino,Y., Kitajima,K., Nakanishi,M. and Adachi,H(1996), "Elasto-Plastic Response Characteristics of Reinforced Concrete Structures Based on Energy Balance," *Transaction of the JCI, Vol.18*, pp.197-204
 3. Kitajima,K., Noguchi,T., Ageta,H. and Suzuki,S. (1996), "A Study on Seismic Retrofit Schemes using Damper to Existing R/C Buildings (Part 1-5)," *Summaries of Technical Paper of Annual Meeting of AIJ, Structure* □, C-2, pp.271-280, (in Japanese)
 4. Noguchi,T., Kitajima,K., Ageta,H. and Adachi,H. (1997), "Experimental Study on Damper-Brace Anchoring Method of R/C Frame for Seismic Retrofit," *Transaction of the JCI, Vol.19*, pp.195-202
- Adachi,H., et al(1985), "Evaluation of Experimental Error Propagation in On-Line Pseudo-Dynamic Testing(Part 1,2)," *Summaries of Technical Paper of Annual Meeting of AIJ, Structure C*, pp.189-192, (in Japanese)