

STUDY ON THE IMPROVEMENT OF ON-LINE TEST APPLYING THE LINEARLY INTERPOLATION METHOD

Kenji KABAYAMA¹

SUMMARY

A displacement control error in a loading test of a specimen is related to a gap between target displacement and achieved displacement of the loaded specimen. This problem is one of the major factors which reduce the accuracy of results of an on-line test. It is a hard task to measure restoring force of a specimen at the target displacement accurately due to the displacement control error, even though the response of the specimen is computed based on the measured restoring force in the on-line test. This paper proposes application of the Linearly Interpolation Method (LIM) to control the influences of displacement control errors in the on-line test. The LIM is a very simple method installed to a loading program without any other devices. This paper also presents availability and efficiency of the LIM through on-line tests and an elasto-plastic dynamic analysis. Displacement control errors are generated during the on-line test in which specimen is an R/C column, and the test parameter is whether the LIM is applied or not. The earthquake response of the specimen with no displacement control error is computed by the elasto-plastic dynamic analysis to be substituted for the true response. The specimen is modeled as a single-degree-of-freedom mass system in the analysis. The response of the test applied the LIM is found very similar to the analytical response, while the result of a test without the LIM is disturbed by displacement control errors.

INTRODUCTION

An on-line test (also referred to as a pseudo-dynamic test) is a hybrid method consisting of a loading test of a specimen (the testing part) and a numerical calculation of earthquake response based on an analytical model of the specimen (the computing part). This technique has been applied to various seismic structural experiments, because of the fact that dynamic characteristics of structures or structural components can be estimated economically utilizing only static loading devices and a personal computer. Regardless of this advantage, the on-line test has some serious problems. One of them is a displacement control error which is a gap between target displacement and achieved displacement of the specimen after loading in the testing part. Some researchers have reported that the displacement control error had potential to disturb results of on-line tests. [1], [2] The author of this paper also investigated the influences of displacement control errors based on results of on-line tests of R/C frames, and proposed application of the Linearly Interpolation Method (LIM) to remove the influences. [3]

This paper presents the influences of displacement control errors on results of on-line tests and the scheme of the LIM proposed to control the influences. Then, on-line tests of R/C columns are reported. Displacement control errors are generated during the tests, and the test parameter is whether the LIM is applied or not. Finally, the efficiency of the LIM is discussed based on the test results comparing with earthquake response of the specimen simulated by an elasto-plastic dynamic analysis of a single-degree-of-freedom mass system.

¹ Department of Structural Engineering, Hiroshima University, Higashi-hiroshima, Japan Email: kaba@ipc.hiroshima-u.ac.jp

DISPLACEMENT CONTROL ERROR AND THE LINEARLY INTERPOLATION METHOD

Influences of Displacement Control Errors on On-line Test

It is a hard task to deform a specimen just to target displacement in a loading test, mainly because positioning ability of the loading device has its own limitation. Therefore, a gap is generated between the target displacement and achieved displacement of the specimen after loading. This gap is referred to as “displacement control error” in this paper. As shown in Figure 1 (a), there are two types in the displacement control error, namely “undershooting error” and “overshooting error”. The displacement control error is one of the major problems to disturb results of on-line tests. Figure 1 (b) shows an incorrect estimation of hysteresis due to an undershooting error. In the on-line test, an allowable region is provided around the target displacement. If the specimen is loaded into this region, the loading is stopped and response of the next step of the specimen is calculated based on the measured restoring force at the achieved point in the computing part. In the case of undershooting error, the restoring force is underestimated and hysteresis in the computing part is separated from actual hysteresis of the specimen as shown in the figure. This incorrect estimation of hysteresis produces interruptive negative hysteresis energy, thus response of the specimen is disturbed. An analytical example of influences of displacement control errors is shown in Figure 1 (c). This figure expresses that earthquake response is distributed in accurately due to undershooting or overshooting errors.

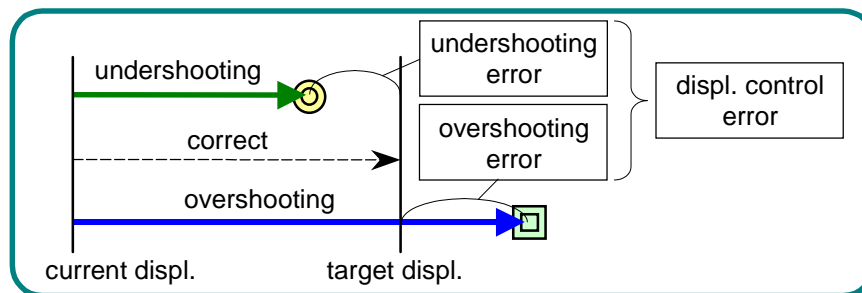

(a) Displacement control error on a loading test

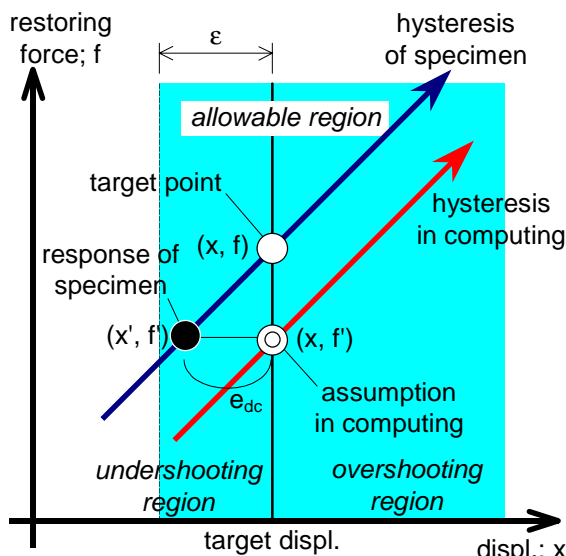

e_{dc} : displ. control error
 ϵ : allowable error for undershooting

(b) Incorrect estimation of hysteresis

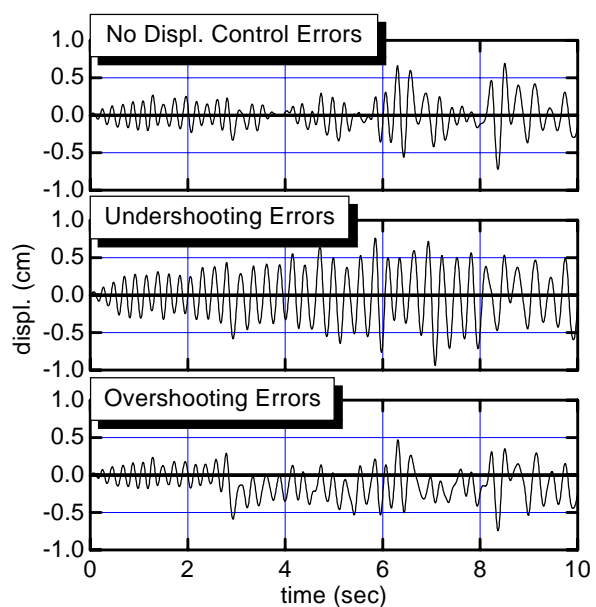

(c) Influences of displacement control errors

Figure 1: Displacement control errors and their influences on response

Scheme of the Linearly Interpolation Method (LIM)

The LIM is a simple technique installed to a loading program in the testing part to obtain the restoring force at the target displacement accurately without any other devices. A concept of this method is shown in Figure 2. The specimen is loaded and deformed over the target displacement, and the restoring force at the target is calculated based on measured data at preceding and following points as shown in this figure. Applying this method, response of the specimen is calculated based on the accurate restoring force in the computing part, however overshooting error is generated in each step of the testing part.

ON-LINE TEST OF R/C COLUMN

Outline of Test

Two on-line tests, i.e. OL95-1 and OL95-2, are carried out to estimate the availability of the LIM. OL95-1 is not installed the LIM and predicted undershooting errors, while OL95-2 is installed and predicted overshooting errors as shown in Table 1. A specimen of each test is an identical R/C column. The test system consists of the testing part and the computing part as shown in Figure 3. In the testing part, an R/C column as a specimen is loaded and deformed, and a personal computer (PC-1) controls devices such as actuators and transducers and records essential data of the devices. In the computing part, the specimen is modeled as a single-degree-of-freedom mass system. A workstation (WS) computes response of the mass based on the restoring force (Q) received from the testing part, and transmits the target displacement (x) of the next step to the testing part.

The testing apparatus and detail of an R/C column as a specimen are shown in Figure 4. The specimen is fixed between a steel base and a steel beam, and loaded by three actuators jointed to the beam. Two vertical actuators control axial force of the specimen to remain at zero level, removing the rotation of the head of the specimen. The specimen is an R/C column (section; 150 x 150 mm, height; 530 mm) having top and bottom stubs (500 x 450 x 300 mm) to connect to the base and the beam.

The specimen is modeled as a single-degree-of-freedom mass system in the computing part as shown in Figure 5. Damping factor is assumed to be 0% to remove the effect of viscous damping. For numerical integration, the Operator Splitting Method [4] is adopted and time interval is 0.001 sec. The EW component of 1987 Chibakentoh-oki Earthquake is input as the ground acceleration.

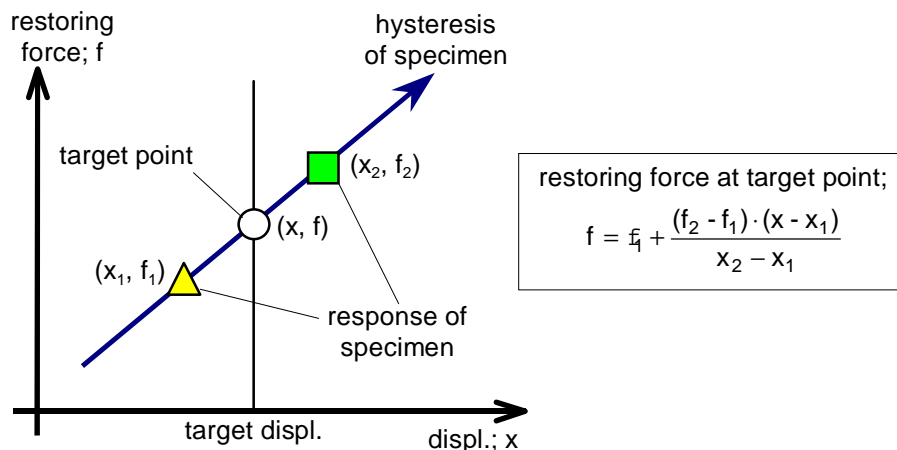

Figure 2: Concept of the Linearly Interpolation Method

Table 1: Test parameter and predicted displacement control error

test name	LIM	predicted displ. control error
OL95-1	not	undershooting error
OL95-2	install	overshooting error

Test Results

Hysteresis curves of both tests are shown in Figure 6 (a). This figure expresses the correlation of horizontal displacement and shearing force of the specimen. Since there is almost no difference in characteristics of the loops, it is indicated that specimens of both tests have identical characteristics. Figure 6 (b) is shown displacement control errors of both tests. Undershooting errors are generated during the test in OL95-1, while overshooting errors in OL95-2, as predicted previously.

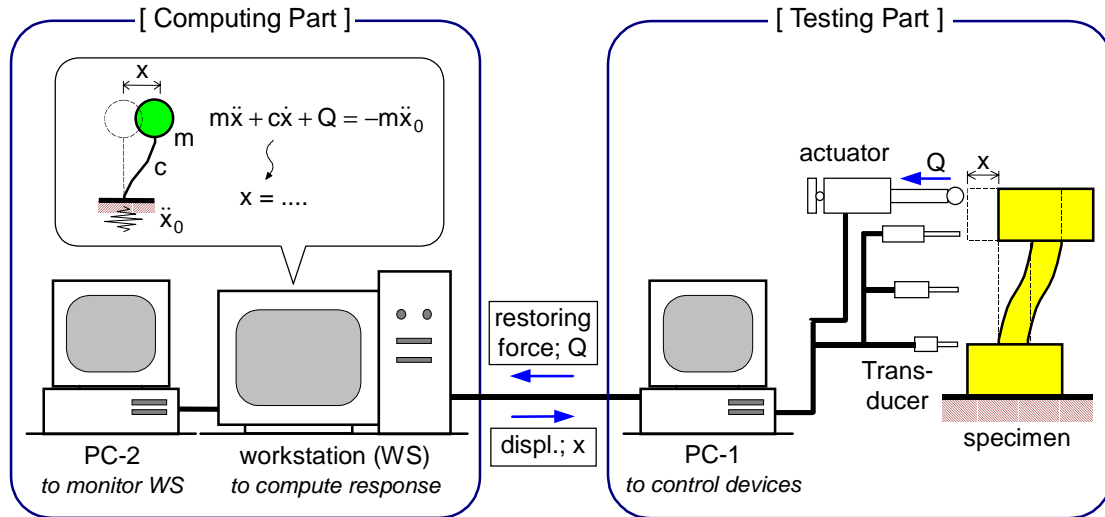

Figure 3: Test system consisting of computing part and testing part

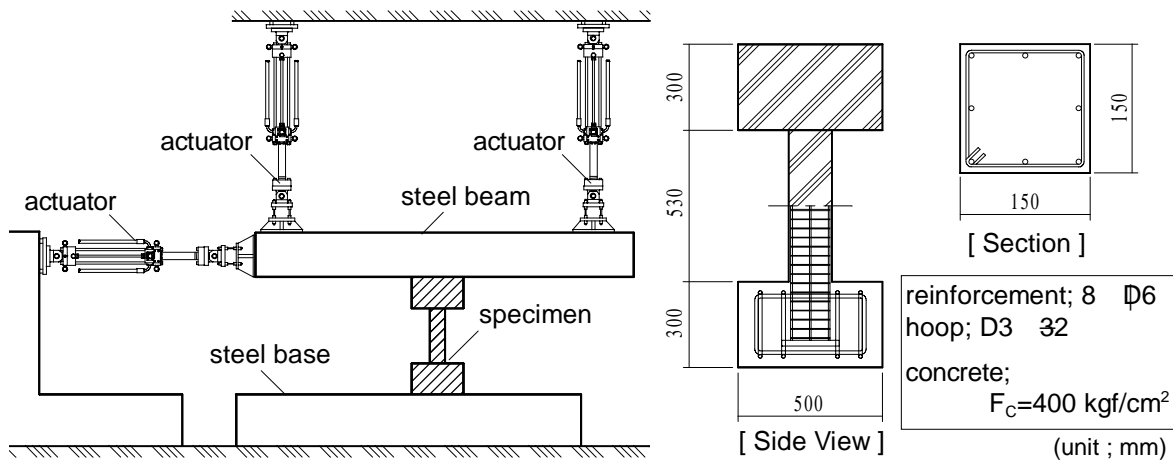

Figure 4: Testing apparatus and detail of R/C column as specimen

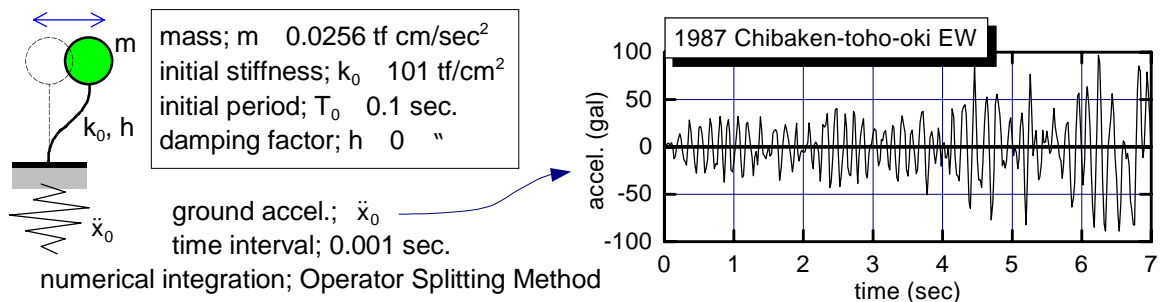

Figure 5: Mass system of specimen and specification for computing part

ANALYTICAL DISCUSSION

To simulate test results, earthquake response of a single-degree-of-freedom mass system is computed by an elasto-plastic dynamic analysis. The specification of the analysis is shown in Table 2. Characteristics of the mass and other conditions are identical to Figure 5. An envelope of hysteresis curves of the test is simplified to tri-linear, and Takeda Model is adopted for the hysteresis characteristic model. Displacement control errors are assumed to be constant in each step, and average of the result of each test is input. Figure 7 shows comparison between responses of the each test and the analysis. The analytical response traces the test result accurately in each case. It is therefore observed that this analytical procedure is suitable to simulate the tests.

The earthquake response with no displacement control error is computed by the above analytical procedure to be substituted for true response of the specimen. The analytical response of the latter case is shown in Figure 8 comparing with the results of both tests. The wave of OL95-2 applied the LIM is found to be similar to the analytical wave with no displacement control error in spite of overshooting errors, although the wave of OL95-1 without the LIM is amplified by undershooting errors. It is evidenced that the LIM is efficient to remove the influences of displacement control errors in an on-line test.

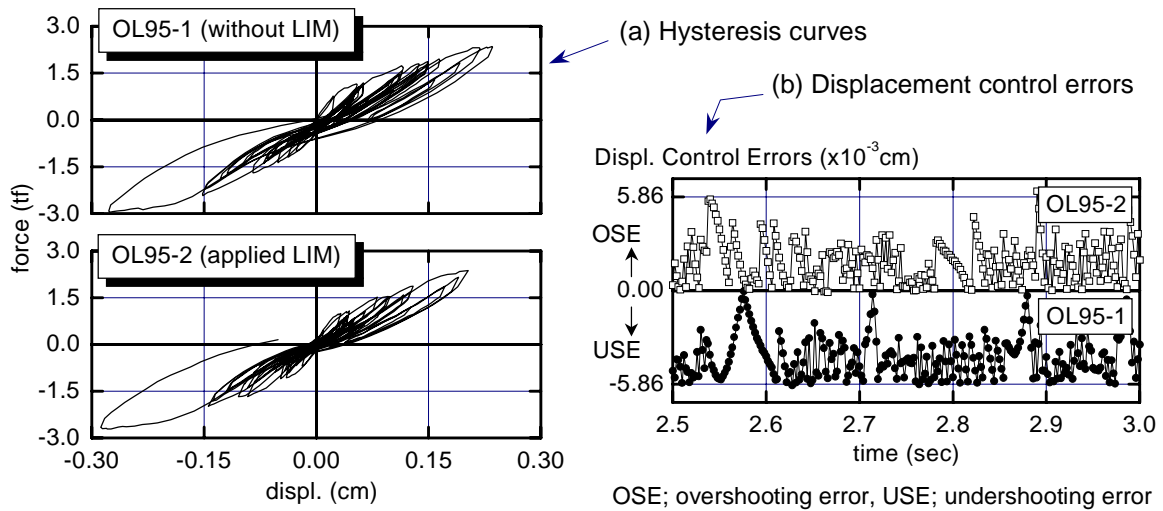

Figure 6: Hysteresis curves and displacement control errors of each test

Table 2: Specification of Analysis

mass and other conditions	; identical to Figure 5
hysteresis characteristics	; Takeda Model
displacement control errors	; constant

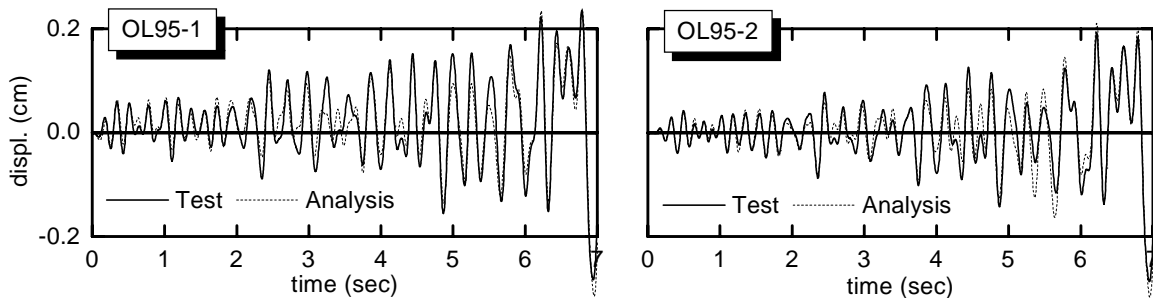

Figure 7: Simulation of test results by analysis

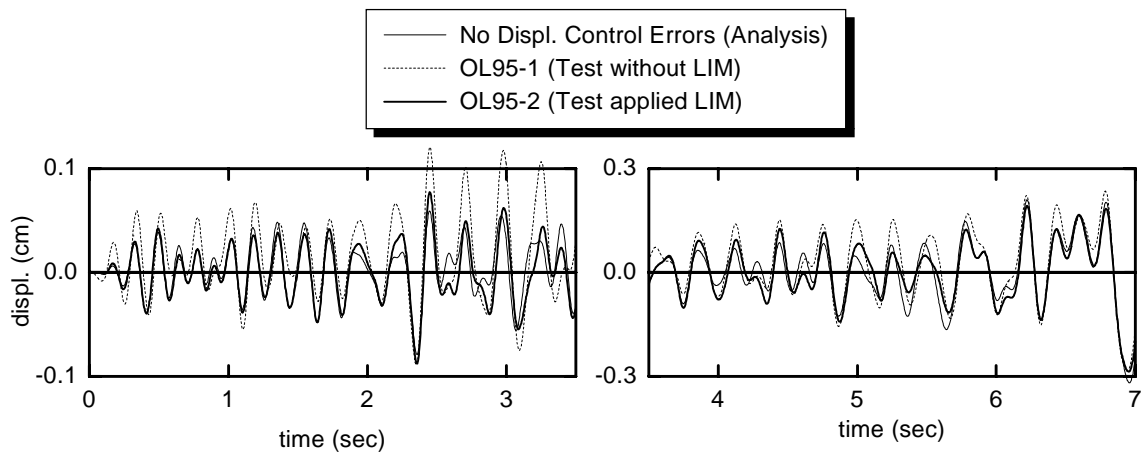

Figure 8: Comparison of test results with analytical response with no displacement control error

CONCLUSION

The displacement control error is one of the major factors reducing the accuracy of an on-line test. This paper proposed the Linearly Interpolation Method to control the influences of the error. Availability and efficiency of the LIM were evidenced through on-line tests of R/C columns and an analytical discussion. It is indicated that applying the LIM can contribute to improve the accuracy of an on-line test.

ACKNOWLEDGEMENT

The Maeda Memorial Foundation sponsored an experimental study in this paper. Much appreciation is expressed for this support. The author is also grateful to supports and advises of Prof. T. Shimazu, Assoc. Prof. H. Araki (Hiroshima Univ.), Dr. F. Kumazawa (Building Research Institute, Ministry of Construction), Assoc. Prof. Y. Nakano (Univ. of Tokyo) and Prof. T. Okada (Shibaura Institute of Tech.).

REFERENCES

- [1] Shing, P.B. and Mahin, S.A. (1983), *Experimental Error Growth in Pseudo Dynamic Testing*, UCB/EERC-83/12, Earthquake Engineering Research Center, Univ. of California, Berkeley.
- [2] Nakashima, M. and Kato, H. (1989), "Control of Experimental Error Growth in Pseudo Dynamic Testing (Stability and Accuracy Behavior of Pseudo Dynamic Response)", *Journal of Structural and Construction Engineering (Transaction of AIJ)*, No.401, pp.129-138.
- [3] Kabayama, K., Toyoshima, M., Kumazawa, F., Nakano, Y. and Okada, T. (1994), "Displacement Control Errors on On-line Tests (The Effect of Undershooting Error)", *Proceeding of 9th Japan Earthquake Engineering Symposium*, Vol.2, pp.1519-1524 (in Japanese).
- [4] Nakashima, M. Ishida, M. and Ando, K. (1990), "Integration Techniques for Substructure Pseudo Dynamic Test (Pseudo Dynamic Test Substructuring Techniques)", *Journal of Structural and Construction Engineering (Transaction of AIJ)*, No.417, pp.107-117.