

CYCLIC RESPONSE OF A NEW STEEL-CONCRETE COMPOSITE FRAME SYSTEM

Riyad S ABOUTAHA¹

SUMMARY

This paper introduces a new steel-concrete hybrid frame system. The frame system consists of steel tubed reinforced concrete columns and ordinary reinforced concrete beams with headed bars. The steel tubed reinforced concrete column is an ordinary reinforced concrete column, however, transversely, it is reinforced with a thin steel tube. The steel tube provides shear resistance, confines the whole concrete cross section, and serves as stay-in-place formwork. In beams, the headed bars are intended to relocate the potential plastic hinge region away from the face of the beam-column joint. Two full-scale steel tubed columns, and two full scale beams with and without headed bars were experimentally investigated. Test results showed that headed bars were effective in moving plastic hinge regions away from the face of the column, however, more research is needed to examine the shear strength of concrete section in plastic hinge region with headed bars. Steel tubed columns investigated in this study exhibited high ductility and energy dissipation when subjected to large lateral displacements, and constant axial loads up to $0.36 A_g f_c'$.

INTRODUCTION

Ductility is an essential property of structures responding inelastically during severe earthquakes. Ductility is defined as the ability of sections, members and structures to deform inelastically without excessive degradation in strength or stiffness. The most common and desirable sources of inelastic structural deformations are rotations in potential plastic hinge regions [Paulay and Priestley, 1992]. An energy dissipation mechanism should be chosen so that the desirable displacement ductility is achieved with smallest rotation demands in the plastic hinges. Development of plastic hinges in frame columns is usually associated with very high rotation demand and may result in total structural instability. While for the same maximum displacement in a structural frame system, the rotation demand in the plastic hinges would be much smaller if they developed in the beams.

For any structural system, a suitable plastic mechanism could be identified, and the regions of potential plastic hinges could be predetermined. These regions should be adequately reinforced to avoid any unfavourable plastic mechanism during an earthquake. In seismic regions, the ideal moment resisting concrete frame system should consist of beams with well-detailed plastic hinges located near column faces, and ductile columns. To avoid unfavourable plastic mechanism in a beam-column joint it is recommended to move the beam plastic hinge region slightly away from the face of the beam-column joint. Also, to ensure superior performance during a seismic event, columns should be able to exhibit good ductility even under high axial loads. Such high ductility can be achieved by the use of steel tubed reinforced concrete columns. Figure 1 shows an elevation view between two floors of the proposed composite hybrid frame system. The frame system consists of steel tubed columns and ordinary reinforced concrete beams with relocated plastic hinges.

¹ Associate Professor, Syracuse University, Civil Eng'g, 235 Hinds Hall, Syracuse, NY 13244, USA. E-mail: rsabouta@syr.edu

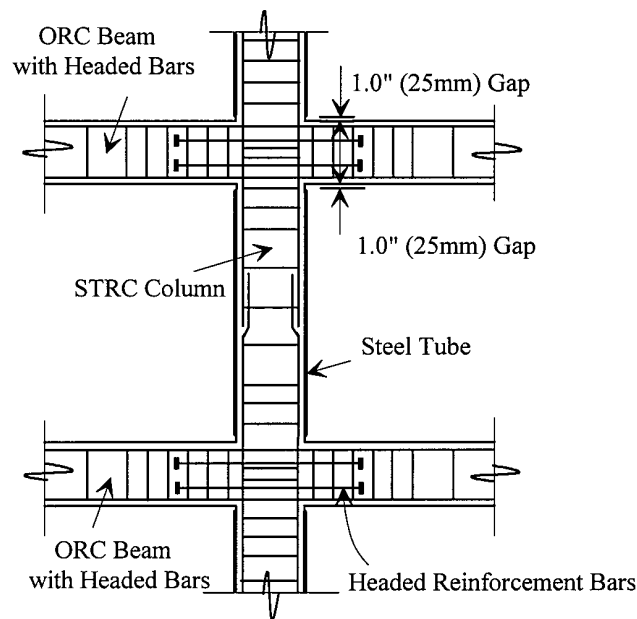

Figure 1 Elevation view between two floors of STRC structural frame system.

In this paper, experimental investigation of two full-scale STRC columns and two beams with headed bars are presented.

RELOCATING POTENTIAL PLASTIC HINGE REGIONS

Locations of plastic hinges in beams should be predetermined since they require special detailing. In an ordinary reinforced concrete frame designed for seismic forces, beam plastic hinges usually develop at the face of the columns. Formation of a plastic hinge at the face of a column results in yielding of the beam reinforcing bars at the face of the column, as well as, into the beam-column joint. Yielding of the reinforcing bars in the beam-column joint results in bond deterioration between the reinforcing bars and the surrounding concrete. Such yielding penetration weakens the truss panel mechanisms for shear transfer across the joint core. It can also lead to tension shift when the bond at the beam longitudinal bars is lost across the entire column depth [Park and Dai, 1988]. In that case, these bars can no longer function as compression reinforcement upon cyclic loading reversal and the strength of the entire frame is drastically reduced. If not well detailed, bond deterioration may even result in structural instability and complete collapse of the structure.

Moving the beam potential plastic hinge slightly away from the face of the column would eliminate bond deterioration between reinforcing bars and the surrounding concrete in the beam-column joint. This can be achieved by detailing the beam so that the ultimate moment to the nominal moment at the plastic hinge is larger than that at the face of the column. In addition, the total nominal moment capacities of beams must be smaller than that of columns at the same beam-column joint, to ensure plastic hinges in the beams only.

Relocating plastic hinges in beams has been investigated in New Zealand and is recommended in the commentary of the New Zealand Standard Code of Practice for the Design of Concrete Structures, NZS 3101 [NZS 3101, 1982]. Relocating plastic hinges in beams has been done by bending some of the longitudinal bars at a predetermined plastic hinge location, or by forming a haunch at the beam end. Figure 2(a&b) shows two traditional details used to relocate plastic hinges in beams away from the face of the column. Both details are not very practical and expensive to construct.

Relocating a plastic hinge in a beam can be easily achieved by the use of headed bars, as presented in this paper. Figure 2(c) shows the details of a beam plastic hinge moved to a predetermined location using headed bars.

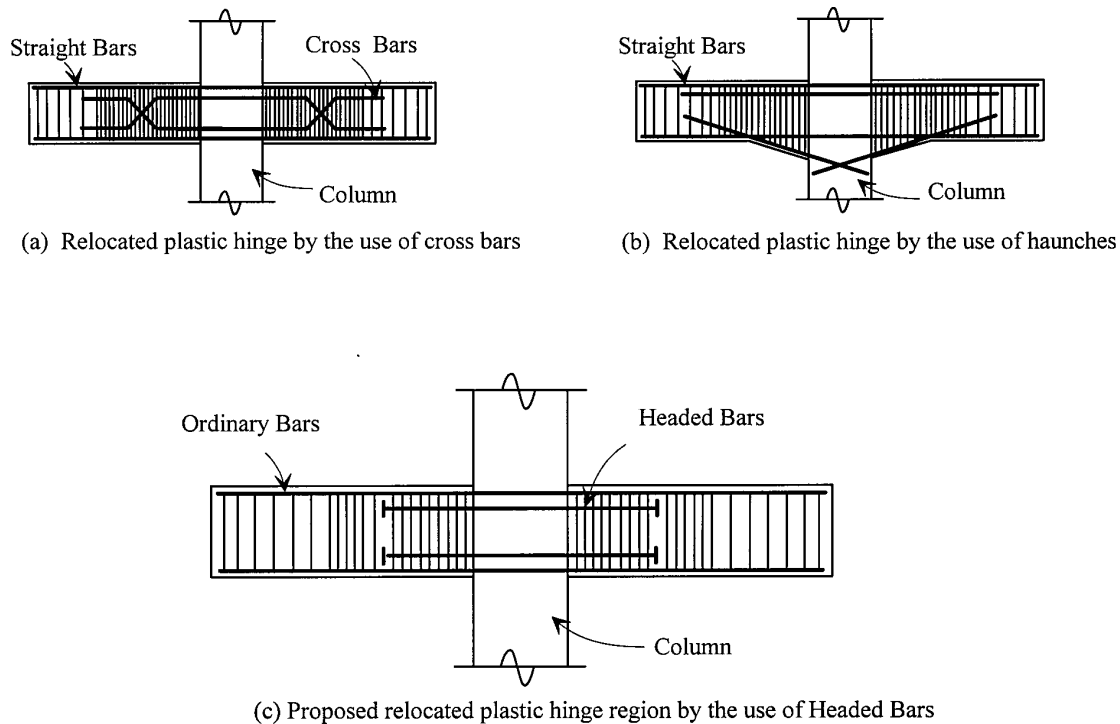

Figure 2 Relocating plastic hinge regions in ordinary reinforced concrete beams.

Moving a beam plastic hinge should be done very carefully. Relocating a plastic hinge will prevent possible problems in the beam-column joint and any other potential stability problems due to joint failure. However, moving the plastic hinge toward the beam midspan will result in an increase in the rotation demand in the hinge. Therefore, the plastic hinge zone should be moved slightly away from the beam-column face to limit rotation demand. This can be successfully accomplished by the use of headed bars. As the required development length of headed bars is much shorter than that of straight bars, moving a plastic hinge zone can be accomplished with shortest development length possible by the use of headed bars. Consequently, the seismic response of reinforced concrete buildings would be less sensitive to relocating the plastic hinge.

STEEL TUBED REINFORCED CONCRETE (STRC) COLUMNS

The current design codes for reinforced concrete structures assure adequate ductility by the use of a sufficient amount of transverse reinforcement and well distributed longitudinal reinforcement. The ordinary reinforcing bars provide good confinement to the concrete. However, the ordinary reinforcing bars do not confine the concrete cover, which may result in spalling of the cover during an earthquake. Spalling of the concrete cover is usually associated with decrease in bond between the steel bars and the surrounding concrete, and degradation of the column's stiffness. In addition, a cross tie with a 90 degree hook tends to loose its effectiveness in bracing longitudinal bars after spalling of the concrete cover, which may result in buckling of the longitudinal bars during an earthquake. The use of steel tube should eliminate such problems.

Concrete filled tube (CFT) columns may be a good alternative to ordinary reinforced concrete (ORC) and structural steel (SS) columns. The steel tube confines the whole concrete section, which results in a more efficient structural section. However, the steel tube of CFT is subjected to compressive axial load, which reduces its effectiveness in confining the concrete core.

EXPERIMENTAL TEST PROGRAM

Two beams detailed according to the current ACI 318-95 Code were constructed and tested under cyclic loading. Figure 3 shows the details of the beams. The test specimen was a cantilever beam. The cross section of the beam was 12" x 20" (304 mm x 508 mm), and reinforced with 8 # 6 (8 - 19 mm diameter) grade 60 bars. Transversely the beam was reinforced with # 4 ties as shown in Figure 3. The concrete strength at the day of

testing was 7.5 ksi. The yield strength of the # 4 transverse ties, #6 ordinary longitudinal, and # 6 headed bars were 40 ksi, 64 ksi, and 68 ksi, respectively. The load was increased in a 5 kip (22 MPa) increments until significant inelastic displacement was recorded. Displacements were then increased in 0.5 % rotation.

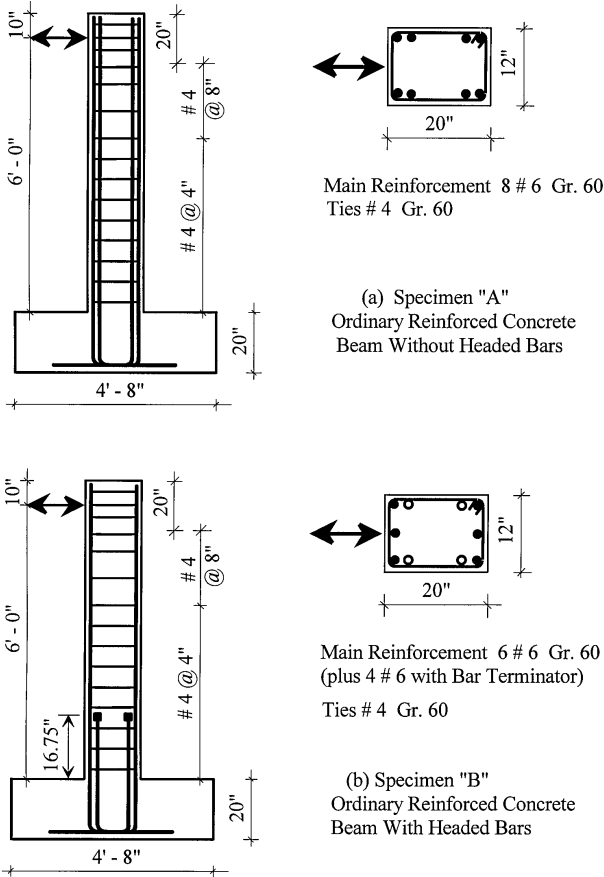

Figure 3 Details of the test beams.

Beam “A” without headed bars exhibited very good response, it maintained its strength to 7 % rotation. However, the steel reinforcing bars yielded at the fixed end of the beam. In a real building frame system, such yielding may result in bond deterioration between the steel bars and the surrounding concrete in the beam-column joint. Figure 4 shows the hysteretic response of the beams “A” and “B”.

Beam “B”, with headed bars, exhibited good ductility, and it maintained its strength to almost 4% rotation. The presence of headed bars allowed partial transfer of tensile force in the longitudinal reinforcement to the headed bars. Consequently reducing the strains in the longitudinal ordinary reinforcing bars. The ultimate failure was in the form of fracture of a transverse tie in the plastic hinge region. Compared to beams without headed bars, the concrete in the plastic hinge region of beam with headed bars is more susceptible to physical deterioration due to the presence of the headed bars in the plastic hinge region. This fact suggests that plastic hinge regions of beams with headed bars may require higher level of confinement and higher amount of shear reinforcement than those of beams without headed bars. It is important to note here that the failure occurred at almost 4 % rotation, which is considered a high rotation.

Figure 5 shows beam “B” after the tests (the beam is oriented upward for ease of testing). As shown in Figure 5, the presence of headed bars shifted the plastic hinge away from the face of the joint, and delayed yielding of the main bars at the face of the joint. It is evident that headed bars could be successfully used to shift plastic hinges in reinforced concrete beams.

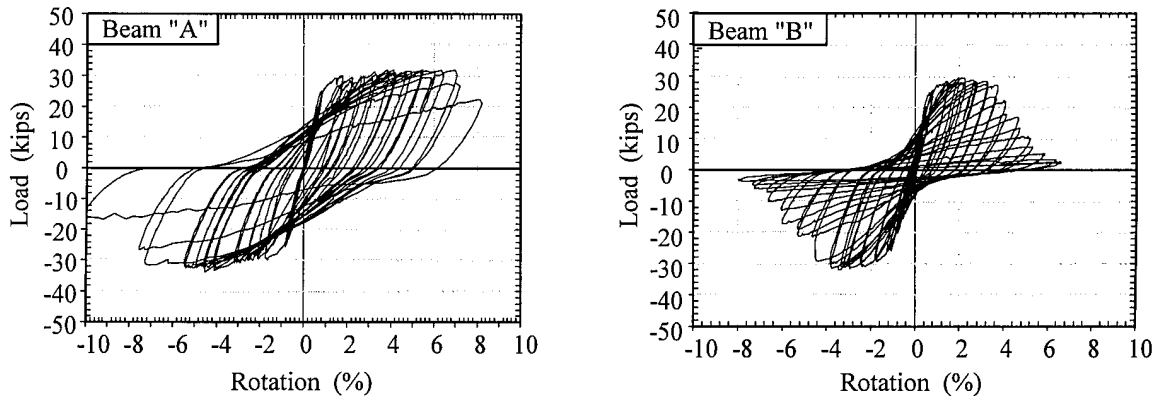

Figure 4 Load – Rotation curves for Beams “A” and “B”.

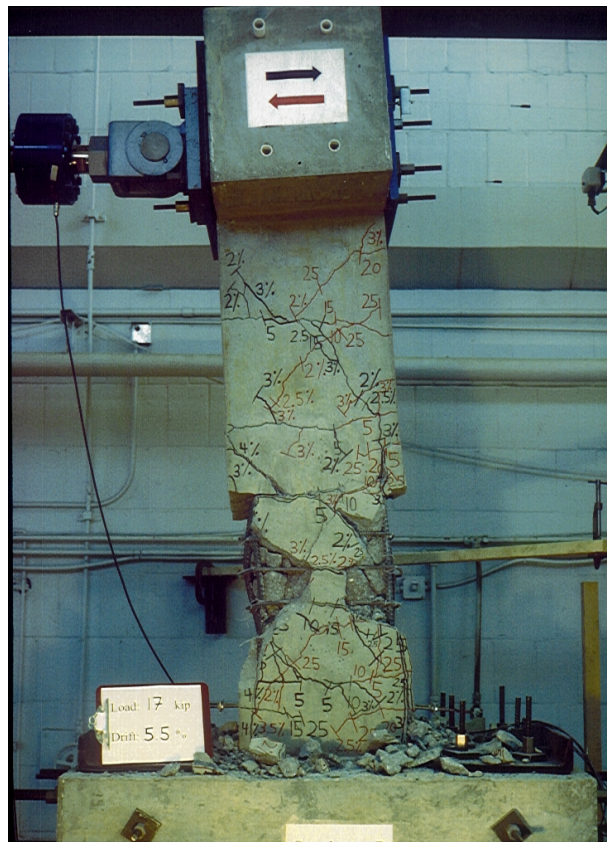

Figure 5 Beam “B”, with headed bars, after the test.

Two full-scale steel tubed reinforced concrete (STRC) columns were investigated. The column size was 12"x20" (300mm x 500mm). The thickness of the steel tube was 5/16" (8 mm). The steel tube was terminated 1.0 inch from the column end. Figure 6 shows the details of the test columns. Although the steel tube did not carry any longitudinal forces, it was terminated at the column ends to prevent any possible bearing of the steel tube against the footing. The columns were tested under two levels of constant axial loads and cyclic lateral load/displacements. The constant axial loads on columns STRC2, and STRC3 were equivalent to 0.25 Agfc' and 0.36 Agfc', respectively. The lateral load was increased in a 5 kip (22 MPa) increments until significant inelastic displacement was recorded. Lateral displacements were then increased in 0.5 % rotation. The concrete strength was 5.1 ksi. The amount of the ordinary transverse reinforcement was very minimal and considerably below the minimum amount required by the current ACI 318-95 Code. Cross ties were also eliminated to allow for better compaction of the concrete core.

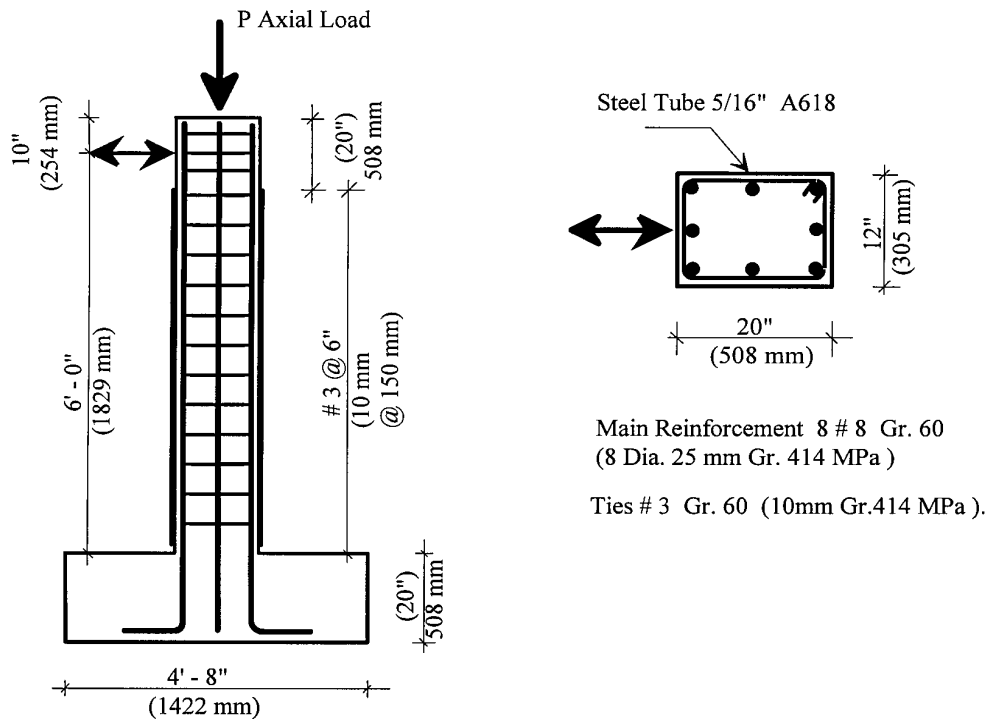

Figure 6 The details of the STRC Columns.

Test results showed that the steel tubed reinforced concrete columns exhibited high strength, ductility and energy dissipation. Figure 7 shows the hysteretic response of the steel tubed column STRC2 and STRC3. As the whole section of the STRC column is confined by the steel tube, the plastic hinge region does not experience serious physical degradation under cyclic loading. Consequently, the steel tubed columns exhibit wide and stable hysteretic loops, as shown in Figure 8. Strains measured on the transverse reinforcing bars showed that the ordinary stirrups yielded. For column STRC2, the maximum lateral load was 84 kips which was achieved at a 4.5 % drift ratio. The test was terminated at about 7% drift ratio where the lateral load was just below 80 kips. For column STRC3, the maximum lateral load was 96 kips which was achieved at a 3.5 % drift ratio. Column STRC3, which had higher axial load, showed higher initial stiffness and ultimate strength than column STRC2.

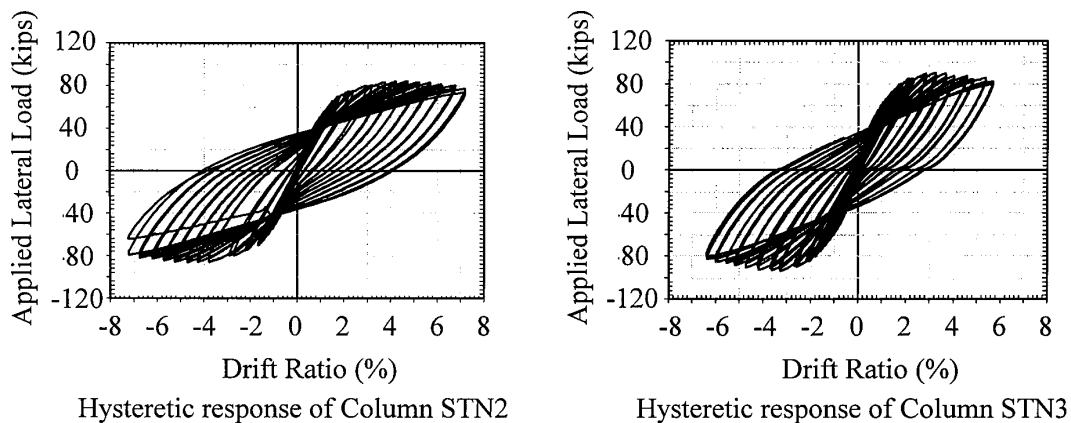

Figure 7 Hysteretic response of the STRC Columns.

CONCLUSIONS

A new steel-concrete hybrid system is introduced. The frame system consists of steel tubed reinforced concrete columns and ordinary reinforced concrete beams with headed bars. The headed bars are intended to relocate the potential plastic hinge region away from the face of the beam-column joint. Test results showed that headed bars were effective in moving the plastic hinge region away from the face of the column, however, more research is needed to examine the shear strength of concrete section in plastic hinge region with headed bars. Steel tubed columns investigated in this study exhibited high ductility and energy dissipation when subjected to large lateral displacements, and axial loads up to $0.36 A_{gfc}$.

ACKNOWLEDGMENTS

The writer gratefully acknowledges the financial support provided by the Portland Cement Association.

REFERENCES

- Paulay, T., and Priestley, M.J.N. (1992) *Seismic Design of Reinforced Concrete and Masonry Buildings*, John Wiley and Sons, New York.
- Park, R., and Dai, R., (1988) "A Comparison of the Behaviour of Reinforced Concrete Beam-Column Joints Designed for Ductility and Limited Ductility," *Bulletin NZNSEE*, 21, 4, pp255-278.
- New Zealand Standard Code of Practice for the Design of Concrete Structures (1982), *NZS 3101: Part 1*, 127 p.; *Commentary NZS 3101: Part 2*, 156 p.; Standard Association of New Zealand, Wellington, New Zealand.