

Document No. :: IITK-GSDMA-EQ21-V2.0
Final Report :: A - Earthquake Codes
IITK-GSDMA Project on Building Codes

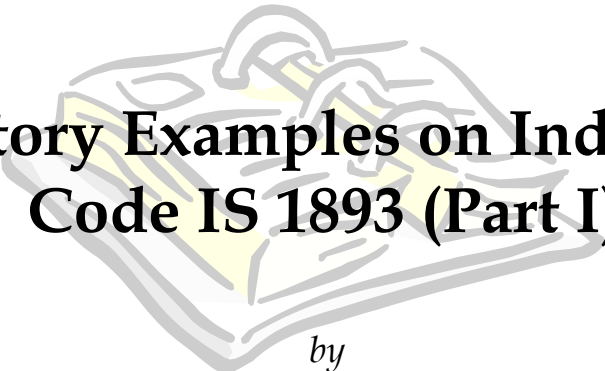

Explanatory Examples on Indian Seismic Code IS 1893 (Part I)

by

Dr. Sudhir K Jain
Department of Civil Engineering
Indian Institute of Technology Kanpur
Kanpur

- The solved examples included in this document are based on a draft code being developed under IITK-GSDMA Project on Building Codes. The draft code is available at <http://www.nicee.org/IITK-GSDMA/IITK-GSDMA.htm> (document number IITK-GSDMA-EQ05-V3.0).
- This document has been developed through the IITK-GSDMA Project on Building Codes.
- The views and opinions expressed are those of the authors and not necessarily of the GSDMA, the World Bank, IIT Kanpur, or the Bureau of Indian Standards.
- Comments and feedbacks may please be forwarded to:
Prof. Sudhir K Jain, Dept. of Civil Engineering, IIT Kanpur, Kanpur 208016, email: nicee@iitk.ac.in

CONTENTS

Sl. No	Title	Page No.
1.	Calculation of Design Seismic Force by Static Analysis Method	4
2.	Calculation of Design Seismic Force by Dynamic Analysis Method	7
3.	Location of Centre of Mass	10
4.	Location of Centre of Stiffness	11
5.	Lateral Force Distribution as per Torsion Provisions of IS 1893-2002 (Part I)	12
6.	Lateral Force Distribution as per New Torsion Provisions	14
7.	Design for Anchorage of an Equipment	16
8.	Anchorage Design for an Equipment Supported on Vibration Isolator	18
9.	Design of a Large Sign Board on a Building	20
10.	Liquefaction Analysis Using SPT Data	21
11.	Liquefaction Analysis Using CPT Data	23

Example 1 – Calculation of Design Seismic Force by Static Analysis Method

Problem Statement:

Consider a four-storey reinforced concrete office building shown in Fig. 1.1. The building is located in Shillong (seismic zone V). The soil conditions are medium stiff and the entire building is supported on a raft foundation. The R. C. frames are infilled with brick-masonry. The lumped weight due to dead loads is 12 kN/m² on floors and 10 kN/m² on the roof. The floors are to cater for a live load of 4 kN/m² on floors and 1.5 kN/m² on the roof. Determine design seismic load on the structure as per new code.

[Problem adopted from Jain S.K, “A Proposed Draft for IS:1893 Provisions on Seismic Design of Buildings; Part II: Commentary and Examples”, Journal of Structural Engineering, Vol.22, No.2, July 1995, pp.73-90]

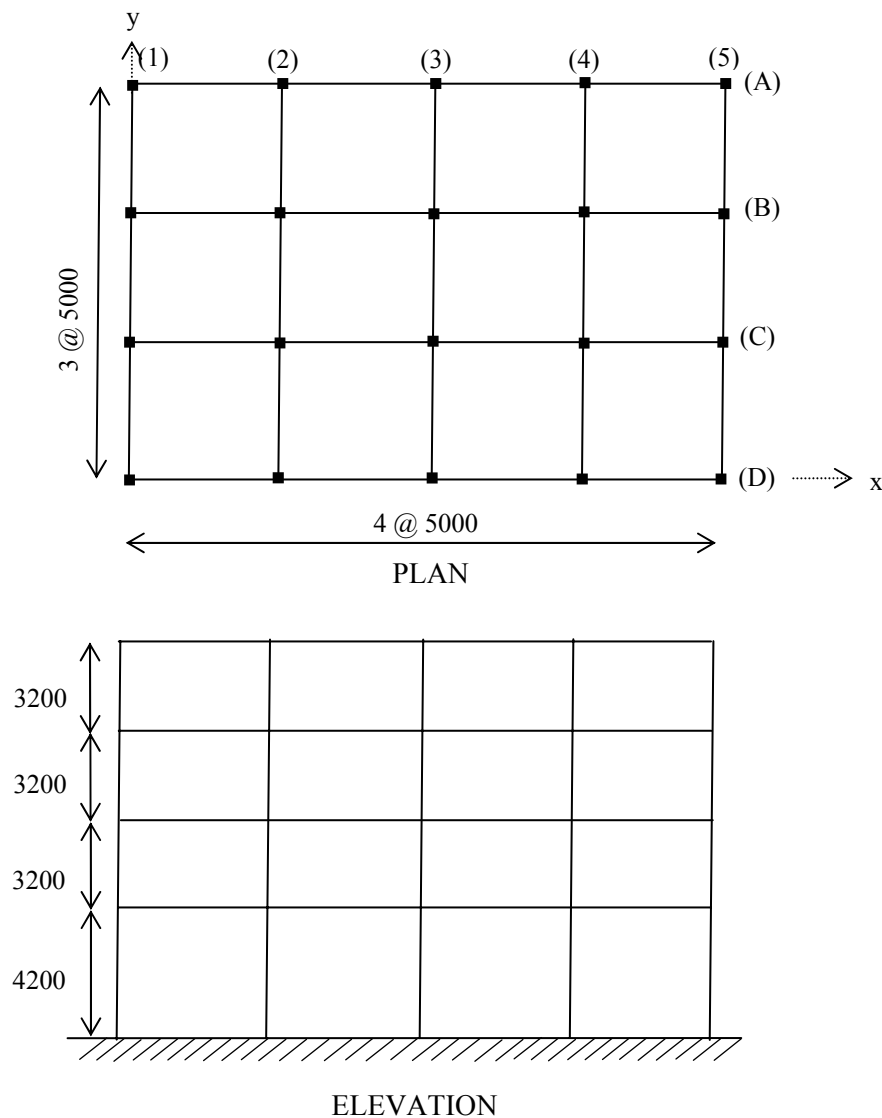

Figure 1.1 – Building configuration

Solution:**Design Parameters:**

For seismic zone V, the zone factor Z is 0.36 (Table 2 of IS: 1893). Being an office building, the importance factor, I , is 1.0 (Table 6 of IS: 1893). Building is required to be provided with moment resisting frames detailed as per IS: 13920-1993. Hence, the response reduction factor, R , is 5.

(Table 7 of IS: 1893 Part 1)

Seismic Weights:

The floor area is $15 \times 20 = 300$ sq. m. Since the live load class is 4kN/sq.m, only 50% of the live load is lumped at the floors. At roof, no live load is to be lumped. Hence, the total seismic weight on the floors and the roof is:

Floors:

$$W_1 = W_2 = W_3 = 300 \times (12 + 0.5 \times 4) = 4,200 \text{ kN}$$

Roof:

$$W_4 = 300 \times 10 = 3,000 \text{ kN}$$

(clause 7.3.1, Table 8 of IS: 1893 Part 1)

Total Seismic weight of the structure,

$$W = \sum W_i = 3 \times 4,200 + 3,000 = 15,600 \text{ kN}$$

Fundamental Period:

Lateral load resistance is provided by moment resisting frames infilled with brick masonry panels. Hence, approximate fundamental natural period:

(Clause 7.6.2. of IS: 1893 Part 1)

EL in X-Direction:

$$T = 0.09h / \sqrt{d}$$

$$= 0.09(13.8) / \sqrt{20} = 0.28 \text{ sec}$$

The building is located on Type II (medium soil).

From Fig. 2 of IS: 1893, for $T=0.28$ sec, $S_a/g = 2.5$

$$A_h = \frac{ZI}{2R} \frac{S_a}{g} = \frac{0.36 \times 1.0}{2 \times 5} \times 2.5 = 0.09$$

(Clause 6.4.2 of IS: 1893 Part 1)

Design base shear

$$V_B = A_h W = 0.09 \times 15,600 = 1,440 \text{ kN}$$

(Clause 7.5.3 of IS: 1893 Part 1)

Force Distribution with Building Height:

The design base shear is to be distributed with height as per clause 7.7.1. Table 1.1 gives the calculations. Fig. 1.2(a) shows the design seismic force in X-direction for the entire building.

EL in Y-Direction:

$$T = 0.09h / \sqrt{d} = 0.09(13.8) / \sqrt{15} = 0.32 \text{ sec}$$

$$\frac{S_a}{g} = 2.5;$$

$$A_h = 0.09$$

Therefore, for this building the design seismic force in Y-direction is same as that in the X-direction. Fig. 1.2(b) shows the design seismic force on the building in the Y-direction.

Table 1.1 – Lateral Load Distribution with Height by the Static Method

Storey Level	W_i (kN)	h_i (m)	$W_i h_i^2 \times (1000)$	$\frac{W_i h_i^2}{\sum W_i h_i^2}$	Lateral Force at i^{th} Level for EL in direction (kN)	
					X	Y
4	3,000	13.8	571.3	0.424	611	611
3	4,200	10.6	471.9	0.350	504	504
2	4,200	7.4	230.0	0.171	246	246
1	4,200	4.2	74.1	0.055	79	79
Σ			1,347.3	1,000	1,440	1,440

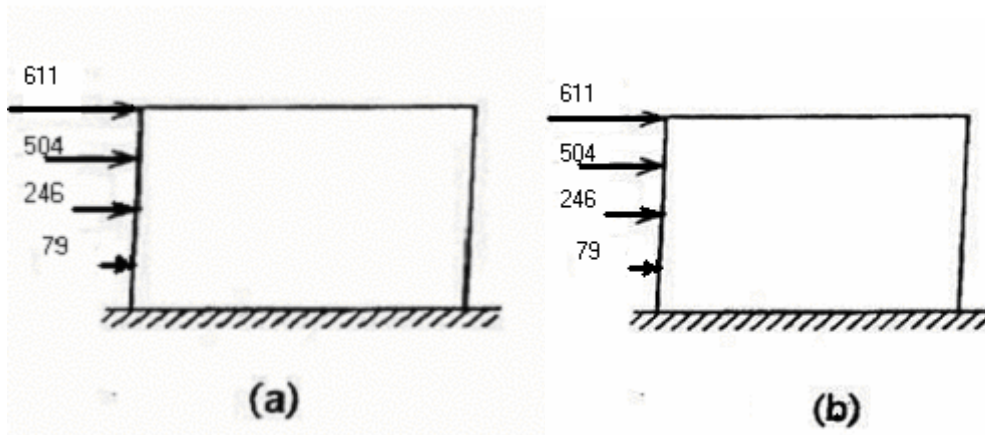

Figure 1.2 -- Design seismic force on the building for (a) X-direction, and (b) Y-direction.

Example 2 – Calculation of Design Seismic Force by Dynamic Analysis Method

Problem Statement:

For the building of Example 1, the dynamic properties (natural periods, and mode shapes) for vibration in the X-direction have been obtained by carrying out a free vibration analysis (Table 2.1). Obtain the design seismic force in the X-direction by the dynamic analysis method outlined in cl. 7.8.4.5 and distribute it with building height.

Table 2.1 – Free Vibration Properties of the building for vibration in the X-Direction

Natural Period (sec)	Mode 1	Mode 2	Mode 3
	0.860	0.265	0.145
Mode Shape			
Roof	1.000	1.000	1.000
3 rd Floor	0.904	0.216	-0.831
2 nd Floor	0.716	-0.701	-0.574
1 st Floor	0.441	-0.921	1.016

[Problem adopted from, Jain S.K, “A Proposed Draft for IS: 1893 Provisions on Seismic Design of Buildings; Part II: Commentary and Examples”, Journal of Structural Engineering, Vol.22, No.2, July 1995, pp.73-90]

Solution:

Table 2.2 -- Calculation of modal mass and modal participation factor (clause 7.8.4.5)

Storey Level i	Weight $W_i(kN)$	Mode 1			Mode 2			Mode 3		
		4	3,000	1.000	3,000	3,000	1.000	3,000	3,000	1.000
3	4,200	0.904	3,797	3,432	0.216	907	196	-0.831	-3,490	2,900
2	4,200	0.716	3,007	2,153	-0.701	-2,944	2,064	-0.574	-2,411	1,384
1	4,200	0.441	1,852	817	-0.921	-3,868	3,563	1.016	4,267	4,335
Σ	15,600		11,656	9,402		-2,905	8,822		1,366	11,620
$M_k = \frac{[\sum w_i \phi_{ik}]^2}{g \sum w_i \phi_{ik}^2}$		$\frac{11,656^2}{9,402g} = \frac{14,450kN}{g} = 14,45,000 \text{ kg}$			$\frac{2,905^2}{8,822g} = \frac{957kN}{g} = 95,700 \text{ kg}$			$\frac{1,366^2}{11,620g} = \frac{161kN}{g} = 16,100 \text{ kg}$		
% of Total weight		92.6%			6.1%			1.0%		
$P_k = \frac{\sum w_i \phi_{ik}}{\sum w_i \phi_{ik}^2}$		$\frac{11,656}{9,402} = 1.240$			$\frac{-2,905}{8,822} = -0.329$			$\frac{1,366}{11,620} = 0.118$		

It is seen that the first mode excites 92.6% of the total mass. Hence, in this case, codal requirements on number of modes to be considered such that at least 90% of the total mass is excited, will be satisfied by considering the first mode of

vibration only. However, for illustration, solution to this example considers the first three modes of vibration.

The lateral load Q_{ik} acting at i^{th} floor in the k^{th} mode is

$$Q_{ik} = A_{hk} \phi_{ik} P_k W_i$$

(clause 7.8.4.5 c of IS: 1893 Part 1)

The value of A_{hk} for different modes is obtained from clause 6.4.2.

Mode 1:

$$T_1 = 0.860 \text{ sec};$$

$$(S_a / g) = \frac{1.0}{0.86} = 1.16;$$

$$\begin{aligned} A_{h1} &= \frac{ZI}{2R}(S_a / g) \\ &= \frac{0.36 \times 1}{2 \times 5} \times (1.16) \\ &= 0.0418 \end{aligned}$$

$$Q_{i1} = 0.0418 \times 1.240 \times \phi_{i1} \times W_i$$

Mode 2:

$$T_2 = 0.265 \text{ sec};$$

$$(S_a / g) = 2.5;$$

$$\begin{aligned} A_{h2} &= \frac{ZI}{2R}(S_a / g) \\ &= \frac{0.36 \times 1}{2 \times 5} \times (2.5) \\ &= 0.09 \end{aligned}$$

$$Q_{i2} = 0.09 \times (-0.329) \times \phi_{i2} \times W_i$$

Mode 3:

$$T_3 = 0.145 \text{ sec};$$

$$(S_a / g) = 2.5;$$

$$\begin{aligned} A_{h3} &= \frac{ZI}{2R}(S_a / g) \\ &= \frac{0.36 \times 1}{2 \times 5} \times (2.5) \\ &= 0.09 \end{aligned}$$

$$Q_{i3} = 0.09 \times (0.118) \times \phi_{i3} \times W_i$$

Table 2.3 summarizes the calculation of lateral load at different floors in each mode.

Table 2.3 – Lateral load calculation by modal analysis method (earthquake in X-direction)

Floor Level <i>i</i>	Weight W_i (kN)	Mode 1			Mode 2			Mode 3		
		ϕ_{i1}	Q_{i1}	V_{i1}	ϕ_{i2}	Q_{i2}	V_{i2}	ϕ_{i3}	Q_{i3}	V_{i3}
4	3,000	1.000	155.5	155.5	1.000	-88.8	-88.8	1.000	31.9	31.9
3	4,200	0.904	196.8	352.3	0.216	-26.8	-115.6	-0.831	-37.1	-5.2
2	4,200	0.716	155.9	508.2	-0.701	87.2	-28.4	-0.574	-25.6	-30.8
1	4,200	0.441	96.0	604.2	-0.921	114.6	86.2	1.016	45.4	14.6

Since all of the modes are well separated (clause 3.2), the contribution of different modes is combined by the SRSS (square root of the sum of the square) method

$$V_4 = [(155.5)^2 + (88.8)^2 + (31.9)^2]^{1/2} = 182 \text{ kN}$$

$$V_3 = [(352.3)^2 + (115.6)^2 + (5.2)^2]^{1/2} = 371 \text{ kN}$$

$$V_2 = [(508.2)^2 + (28.4)^2 + (30.8)^2]^{1/2} = 510 \text{ kN}$$

$$V_1 = [(604.2)^2 + (86.2)^2 + (14.6)^2]^{1/2} = 610 \text{ kN}$$

(Clause 7.8.4.4a of IS: 1893 Part 1)

The externally applied design loads are then obtained as:

$$Q_4 = V_4 = 182 \text{ kN}$$

$$Q_3 = V_3 - V_4 = 371 - 182 = 189 \text{ kN}$$

$$Q_2 = V_2 - V_3 = 510 - 371 = 139 \text{ kN}$$

$$Q_1 = V_1 - V_2 = 610 - 510 = 100 \text{ kN}$$

(Clause 7.8.4.5f of IS: 1893 Part 1)

Clause 7.8.2 requires that the base shear obtained by dynamic analysis ($V_B = 610 \text{ kN}$) be compared with that obtained from empirical fundamental period as per Clause 7.6. If V_B is less than that from empirical value, the response quantities are to be scaled up.

We may interpret “base shear calculated using a fundamental period as per 7.6” in two ways:

1. We calculate base shear as per Cl. 7.5.3. This was done in the previous example for the same building and we found the base shear as 1,404 kN. Now, dynamic analysis gives us base shear of 610 kN which is lower. Hence, all the response quantities are to be scaled up in the ratio (1,404/610 = 2.30). Thus, the seismic forces obtained above by dynamic analysis should be scaled up as follows:

$$Q_4 = 182 \times 2.30 = 419 \text{ kN}$$

$$Q_3 = 189 \times 2.30 = 435 \text{ kN}$$

$$Q_2 = 139 \times 2.30 = 320 \text{ kN}$$

$$Q_1 = 100 \times 2.30 = 230 \text{ kN}$$

$$= 1,303 \text{ kN}$$

2. We may also interpret this clause to mean that we redo the dynamic analysis but replace the fundamental time period value by T_a (= 0.28 sec). In that case, for mode 1:

$$T_1 = 0.28 \text{ sec;}$$

$$(S_a / g) = 2.5,$$

$$A_{hi} = \frac{ZI}{2R} (S_a / g) = 0.09$$

$$\begin{aligned} \text{Modal mass times } A_{hi} &= 14,450 \times 0.09 \\ &= 1,300 \text{ kN} \end{aligned}$$

Base shear in modes 2 and 3 is as calculated earlier: Now, base shear in first mode of vibration = 1300 kN, 86.2 kN and 14.6 kN, respectively.

Total base shear by SRSS

$$= \sqrt{1300^2 + 86.2^2 + 14.6^2}$$

Notice that most of the base shear is contributed by first mode only. In this interpretation of Cl 7.8.2, we need to scale up the values of response quantities in the ratio (1,303/610 = 2.14). For instance, the external seismic forces at floor levels will now be:

$$Q_4 = 182 \times 2.14 = 389 \text{ kN}$$

$$Q_3 = 189 \times 2.14 = 404 \text{ kN}$$

$$Q_2 = 139 \times 2.14 = 297 \text{ kN}$$

$$Q_1 = 100 \times 2.14 = 214 \text{ kN}$$

Clearly, the second interpretation gives about 10% lower forces. We could make either interpretation. Herein we will proceed with the values from the second interpretation and compare the design values with those obtained in Example 1 as per static analysis:

Table 2.4 – Base shear at different storeys

Floor Level <i>i</i>	<i>Q</i> (static)	<i>Q</i> (dynamic, scaled)	Storey Shear <i>V</i> (static)	Storey Shear <i>V</i> (dynamic, scaled)	Storey Moment, <i>M</i> (Static)	Storey Moment, <i>M</i> (Dynamic)
4	611 kN	389 kN	611 kN	389 kN	1,907 kNm	1,245 kNm
3	504 kN	404 kN	1,115 kN	793 kN	5,386 kNm	3,782 kNm
2	297 kN	297 kN	1,412 kN	1,090 kN	9,632 kNm	7,270 kNm
1	79 kN	214 kN	1,491 kN	1,304 kN	15,530 kNm	12,750 kNm

Notice that even though the base shear by the static and the dynamic analyses are comparable, there is considerable difference in the lateral load distribution with building height, and therein lies the advantage of dynamic analysis. For instance, the storey moments are significantly affected by change in load distribution.

Example 3 – Location of Centre of Mass

Problem Statement:

Locate centre of mass of a building having non-uniform distribution of mass as shown in the figure 3.1

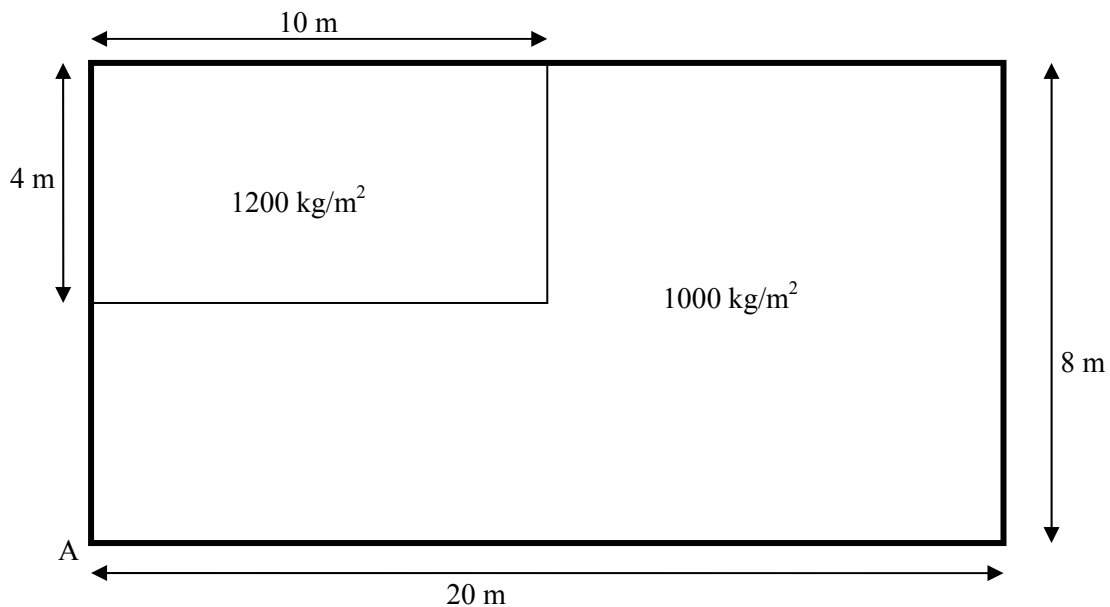

Figure 3.1 –Plan

Solution:

Let us divide the roof slab into three rectangular parts as shown in figure 2.1

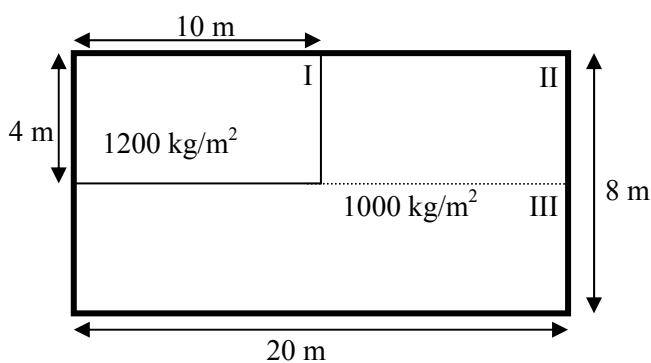

Figure 3.2

Mass of part I is 1200 kg/m^2 , while that of the other two parts is 1000 kg/m^2 .

Let origin be at point A, and the coordinates of the centre of mass be at (X, Y)

$$X = \frac{(10 \times 4 \times 1200) \times 5 + (10 \times 4 \times 1000) \times 15 + (20 \times 4 \times 1000) \times 10}{(10 \times 4 \times 1200) + (10 \times 4 \times 1000) + (20 \times 4 \times 1000)}$$

$$= 9.76 \text{ m}$$

$$Y = \frac{(10 \times 4 \times 1200) \times 6 + (10 \times 4 \times 1000) \times 6 + (20 \times 4 \times 1000) \times 2}{(10 \times 4 \times 1200) + (10 \times 4 \times 1000) + (20 \times 4 \times 1000)}$$

$$= 4.1 \text{ m}$$

Hence, coordinates of centre of mass are (9.76, 4.1)

Example 4 – Location of Centre of Stiffness

Problem Statement:

The plan of a simple one storey building is shown in figure 3.1. All columns and beams are same. Obtain its centre of stiffness.

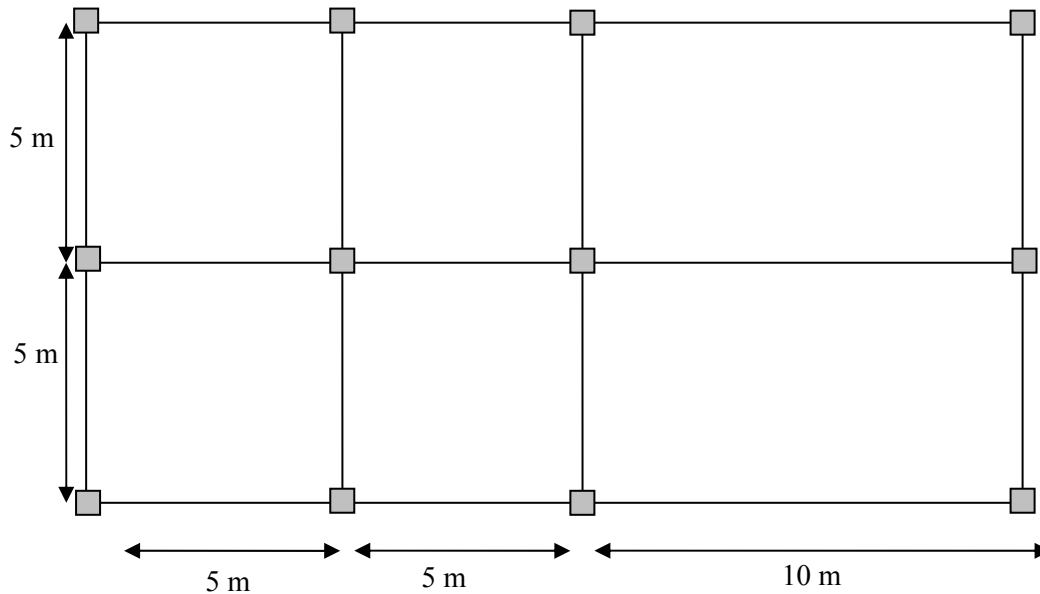

Figure 4.1 –Plan

Solution:

In the X-direction there are three identical frames located at uniform spacing. Hence, the y-coordinate of centre of stiffness is located symmetrically, i.e., at 5.0 m from the left bottom corner.

In the Y-direction, there are four identical frames having equal lateral stiffness. However, the spacing is not uniform. Let the lateral stiffness of each transverse frame be k , and coordinating of center of stiffness be (X, Y) .

$$X = \frac{k \times 0 + k \times 5 + k \times 10 + k \times 20}{k + k + k + k} = 8.75 \text{ m}$$

Hence, coordinates of centre of stiffness are $(8.75, 5.0)$.

Example 5 –Lateral Force Distribution as per Torsion Provisions of IS 1893-2002 (Part 1)

Problem Statement:

Consider a simple one-storey building having two shear walls in each direction. It has some gravity columns that are not shown. All four walls are in M25 grade concrete, 200 thick and 4 m long. Storey height is 4.5 m. Floor consists of cast-in-situ reinforced concrete. Design shear force on the building is 100 kN in either direction.

Compute design lateral forces on different shear walls using the torsion provisions of 2002 edition of IS 1893 (Part 1).

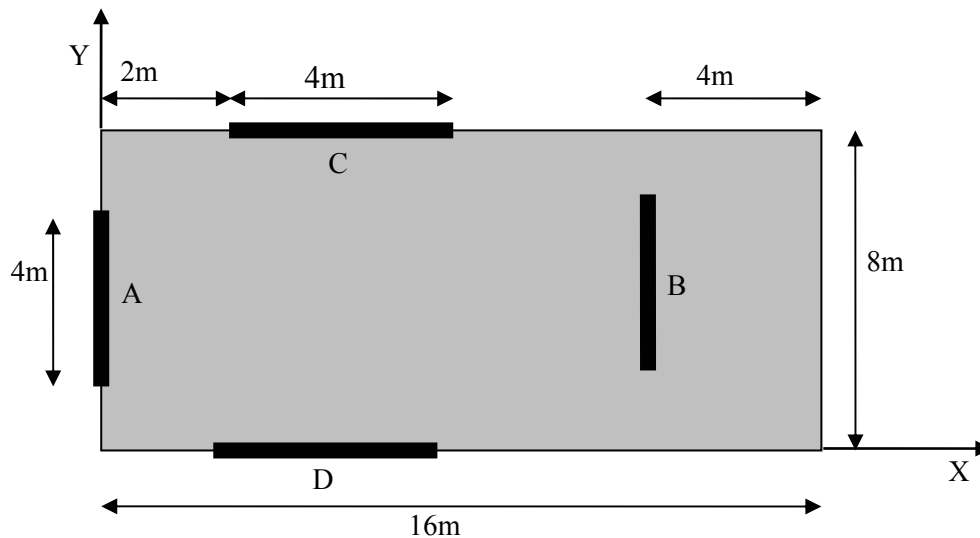

Figure 5.1 – Plan

Solution:

Grade of concrete: M25

$$E = 5000\sqrt{25} = 25000 \text{ N/mm}^2$$

Storey height $h = 4500 \text{ m}$

Thickness of wall $t = 200 \text{ mm}$

Length of walls $L = 4000 \text{ mm}$

All walls are same, and hence, spaces have same lateral stiffness, k .

Centre of mass (CM) will be the geometric centre of the floor slab, i.e., (8.0, 4.0).

Centre of rigidity (CR) will be at (6.0, 4.0).

EQ Force in X-direction:

Because of symmetry in this direction, calculated eccentricity = 0.0 m

Design eccentricity:

$$e_d = 1.5 \times 0.0 + 0.05 \times 8 = 0.4,$$

and

$$e_d = 0.0 - 0.05 \times 8 = -0.4$$

(Clause 7.9.2 of IS 1893:2002)

Lateral forces in the walls due to translation:

$$F_{CT} = \frac{K_C}{K_C + K_D} F = 50.0 \text{ kN}$$

$$F_{DT} = \frac{K_D}{K_C + K_D} F = 50.0 \text{ kN}$$

Lateral forces in the walls due to torsional moment:

$$F_{iT} = \frac{K_i r_i}{\sum_{i=A,B,C,D} K_i r_i^2} (F e_d)$$

where r_i is the distance of the shear wall from CR.

All the walls have same stiffness, $K_A = K_B = K_C = K_D = k$, and

$$r_A = -6.0 \text{ m}$$

$$r_B = -6.0 \text{ m}$$

$$r_C = 4.0 \text{ m}$$

$$r_D = -4.0 \text{ m,}$$

$$\text{and } e_d = \pm 0.4 \text{ m}$$

Therefore,

$$F_{AR} = \frac{r_A k}{(r_A^2 + r_B^2 + r_C^2 + r_D^2)k} (F e_d)$$

$$= \pm 2.31 \text{ kN}$$

Similarly,

$$F_{BR} = \pm 2.31 \text{ kN}$$

$$F_{CR} = \pm 1.54 \text{ kN}$$

$$F_{DR} = \pm 1.54 \text{ kN}$$

Total lateral forces in the walls due to seismic load in X direction:

$$F_A = 2.31 \text{ kN}$$

$$F_B = 2.31 \text{ kN}$$

$$F_C = \text{Max } (50 \pm 1.54) = 51.54 \text{ kN}$$

$$F_D = \text{Max } (50 \pm 1.54) = 51.54 \text{ kN}$$

EQ Force in Y-direction:

Calculated eccentricity = 2.0 m

Design eccentricity:

$$e_d = 1.5 \times 2.0 + 0.05 \times 16 = 3.8 \text{ m}$$

$$\text{or } = 2.0 - 0.05 \times 16 = 1.2 \text{ m}$$

Lateral forces in the walls due to translation:

$$F_{AT} = \frac{K_A}{K_A + K_B} F = 50.0 \text{ kN}$$

$$F_{BT} = \frac{K_B}{K_A + K_B} F = 50.0 \text{ kN}$$

Lateral force in the walls due to torsional moment: when $e_d = 3.8 \text{ m}$

$$F_{AR} = \frac{r_A k}{(r_A^2 + r_B^2 + r_C^2 + r_D^2)k} (F e_d) = -$$

21.92 kN

Similarly,

$$F_{BR} = 21.92 \text{ kN}$$

$$F_{CR} = -14.62 \text{ kN}$$

$$F_{DR} = 14.62 \text{ kN}$$

Total lateral forces in the walls:

$$F_A = 50 - 21.92 = 28.08 \text{ kN}$$

$$F_B = 50 + 20.77 = 71.92 \text{ kN}$$

$$F_C = -14.62 \text{ kN}$$

$$F_D = 14.62 \text{ kN}$$

Similarly, when $e_d = 1.2 \text{ m}$, then the total lateral forces in the walls will be,

$$F_A = 50 - 6.93 = 43.07 \text{ kN}$$

$$F_B = 50 + 6.93 = 56.93 \text{ kN}$$

$$F_C = -4.62 \text{ kN}$$

$$F_D = 4.62 \text{ kN}$$

Maximum forces in walls due to seismic load in Y direction:

$$F_A = \text{Max } (28.08, 43.07) = 43.07 \text{ kN};$$

$$F_B = \text{Max } (71.92, 56.93) = 71.92 \text{ kN};$$

$$F_C = \text{Max } (14.62, 4.62) = 14.62 \text{ kN};$$

$$F_D = \text{Max } (14.62, 4.62) = 14.62 \text{ kN};$$

Combining the forces obtained from seismic loading in X and Y directions:

$$F_A = 43.07 \text{ kN}$$

$$F_B = 71.92 \text{ kN}$$

$$F_C = 51.54 \text{ kN}$$

$$F_D = 51.54 \text{ kN}.$$

However, note that clause 7.9.1 also states that "However, negative torsional shear shall be neglected". Hence, wall A should be designed for not less than 50 kN.

Example 6 – Lateral Force Distribution as per New Torsion Provisions

Problem Statement:

For the building of example 5, compute design lateral forces on different shear walls using the torsion provisions of revised draft code IS 1893 (part 1), i.e., IITK-GSDMA-EQ05-V2.0.

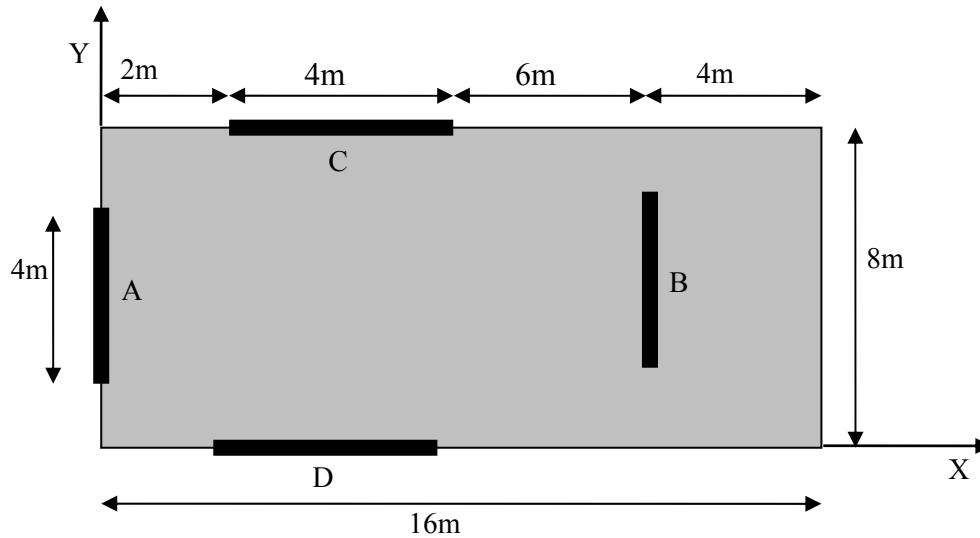

Figure 6.1 – Plan

Solution:

Grade of concrete: M25

$$E = 5000\sqrt{25} = 25000 \text{ N/mm}^2$$

Storey height $h = 4500 \text{ m}$

Thickness of wall $t = 200 \text{ mm}$

Length of walls $L = 4000 \text{ mm}$

All walls are same, and hence, same lateral stiffness, k .

Centre of mass (CM) will be the geometric centre of the floor slab, i.e., (8.0, 4.0).

Centre of rigidity (CR) will be at (6.0, 4.0).

EQ Force in X-direction:

Because of symmetry in this direction, calculated eccentricity = 0.0 m

Design eccentricity, $e_d = 0.0 \pm 0.1 \times 8 = \pm 0.8$
(clause 7.9.2 of Draft IS 1893: (Part1))

Lateral forces in the walls due to translation:

$$F_{CT} = \frac{K_C}{K_C + K_D} F = 50.0 \text{ kN}$$

$$F_{DT} = \frac{K_D}{K_C + K_D} F = 50.0 \text{ kN}$$

Lateral forces in the walls due to torsional moment:

$$F_{iR} = \frac{K_i r_i}{\sum_{i=A,B,C,D} K_i r_i^2} (F e_d)$$

where r_i is the distance of the shear wall from CR

All the walls have same stiffness, $K_A = K_B = K_C = K_D = k$

$$r_A = -6.0 \text{ m}$$

$$r_B = -6.0 \text{ m}$$

$$r_C = 4.0 \text{ m}$$

$$r_D = -4.0 \text{ m}$$

$$F_{AR} = \frac{r_A k}{(r_A^2 + r_B^2 + r_C^2 + r_D^2) k} (F e_d)$$

$$= -4.62 \text{ kN}$$

Similarly,

$$F_{BR} = 4.62 \text{ kN}$$

$$F_{CR} = 3.08 \text{ kN}$$

$$F_{DR} = -3.08 \text{ kN}$$

Total lateral forces in the walls:

$$F_A = 4.62 \text{ kN}$$

$$F_B = -4.62 \text{ kN}$$

$$F_C = 50 + 3.08 = 53.08 \text{ kN}$$

$$F_D = 50 - 3.08 = 46.92 \text{ kN}$$

Similarly, when $e_d = -0.8$ m, then the lateral forces in the walls will be,

$$F_A = -4.62 \text{ kN}$$

$$F_B = 4.62 \text{ kN}$$

$$F_C = 50 - 3.08 = 46.92 \text{ kN}$$

$$F_D = 50 + 3.08 = 53.08 \text{ kN}$$

Design lateral forces in walls C and D are:

$$F_C = F_D = 53.05 \text{ kN}$$

EQ Force in Y-direction:

Calculated eccentricity = 2.0 m

Design eccentricity,

$$e_d = 2.0 + 0.1 \times 16 = 3.6 \text{ m}$$

or

$$e_d = 2.0 - 0.1 \times 16 = 0.4 \text{ m}$$

Lateral forces in the walls due to translation:

$$F_{AT} = \frac{K_A}{K_A + K_B} F = 50.0 \text{ kN}$$

$$F_{BT} = \frac{K_B}{K_A + K_B} F = 50.0 \text{ kN}$$

Lateral force in the walls due to torsional moment: when $e_d = 3.6$ m

$$F_{AR} = \frac{r_A k}{(r_A^2 + r_B^2 + r_C^2 + r_D^2)k} (F e_d) =$$

$$20.77 \text{ kN}$$

Similarly,

$$F_{BR} = 20.77 \text{ kN}$$

$$F_{CR} = 13.85 \text{ kN}$$

$$F_{DR} = -13.8 \text{ kN}$$

Total lateral forces in the walls:

$$F_A = 50 - 20.77 = 29.23 \text{ kN}$$

$$F_B = 50 + 20.77 = 70.77 \text{ kN}$$

$$F_C = 13.85 \text{ kN}$$

$$F_D = -13.85 \text{ kN}$$

Similarly, when $e_d = 0.4$ m, then the total lateral forces in the walls will be,

$$F_A = 50 - 2.31 = 47.69 \text{ kN}$$

$$F_B = 50 + 2.31 = 53.31 \text{ kN}$$

$$F_C = 1.54 \text{ kN}$$

$$F_D = -1.54 \text{ kN}$$

Maximum forces in walls A and B

$$F_A = 47.69 \text{ kN}, F_B = 70.77 \text{ kN}$$

Design lateral forces in all the walls are as follows:

$$F_A = 47.69 \text{ kN}$$

$$F_B = 70.77 \text{ kN}$$

$$F_C = 53.05 \text{ kN}$$

$$F_D = 53.05 \text{ kN}.$$

Example 7 – Design for Anchorage of an Equipment

Problem Statement:

A 100 kN equipment (Figure 7.1) is to be installed on the roof of a five storey building in Simla (seismic zone IV). It is attached by four anchored bolts, one at each corner of the equipment, embedded in a concrete slab. Floor to floor height of the building is 3.0 m, except the ground storey which is 4.2 m. Determine the shear and tension demands on the anchored bolts during earthquake shaking.

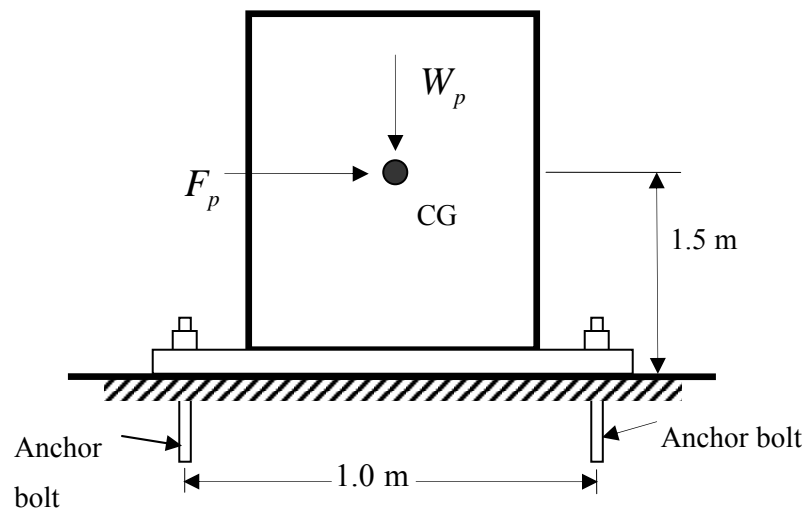

Figure 7.1– Equipment installed at roof

Solution:

Zone factor, $Z = 0.24$ (for zone IV, Table 2 of IS 1893),

Height of point of attachment of the equipment above the foundation of the building, $x = (4.2 + 3.0 \times 4) \text{ m} = 16.2 \text{ m}$,

Height of the building, $h = 16.2 \text{ m}$,

Amplification factor of the equipment, $a_p = 1$ (rigid component, Table 11),

Response modification factor $R_p = 2.5$ (Table 11),

Importance factor $I_p = 1$ (not life safety component, Table 12),

Weight of the equipment, $W_p = 100 \text{ kN}$

The design seismic force

$$F_p = \frac{Z}{2} \left(1 + \frac{x}{h} \right) \frac{a_p}{R_p} I_p W_p$$

$$= \frac{0.24}{2} \left(1 + \frac{16.2}{16.2} \right) \frac{1.0}{2.5} (1) (100) \text{ kN}$$

$$= 9.6 \text{ kN} < 0.1W_p = 10.0 \text{ kN}$$

Hence, design seismic force, for the equipment

$$F_p = 10.0 \text{ kN.}$$

The anchorage of equipment with the building must be designed for twice of this force (Clause 7.13.3.4 of draft IS 1893)

$$\begin{aligned}\text{Shear per anchor bolt, } V &= 2F_p/4 \\ &= 2 \times 10.0/4 \text{ kN} \\ &= 5.0 \text{ kN}\end{aligned}$$

The overturning moment is

$$\begin{aligned}M_{ot} &= 2.0 \times (10.0 \text{ kN}) \times (1.5 \text{ m}) \\ &= 30.0 \text{ kN-m}\end{aligned}$$

The overturning moment is resisted by two anchor bolts on either side. Hence, tension per anchor bolt from overturning is

$$\begin{aligned}F_t &= \frac{(30.0)}{(1.0)(2)} \text{ kN} \\ &= 15.0 \text{ kN}\end{aligned}$$

Example 8 – Anchorage Design for an Equipment Supported on Vibration Isolator

Problem Statement:

A 100 kN electrical generator of a emergency power supply system is to be installed on the fourth floor of a 6-storey hospital building in Guwahati (zone V). It is to be mounted on four flexible vibration isolators, one at each corner of the unit, to damp the vibrations generated during the operation. Floor to floor height of the building is 3.0 m. except the ground storey which is 4.2 m. Determine the shear and tension demands on the isolators during earthquake shaking.

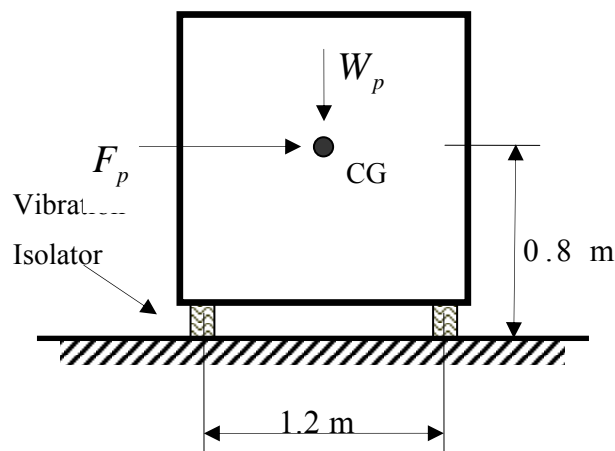

Figure 8.1 – Electrical generator installed on the floor

Solution:

Zone factor, $Z = 0.36$ (for zone V, Table 2 of IS 1893),

Height of point of attachment of the generator above the foundation of the building,

$$x = (4.2 + 3.0 \times 3) \text{ m} \\ = 13.2 \text{ m},$$

Height of the building,

$$h = (4.2 + 3.0 \times 5) \text{ m} \\ = 19.2 \text{ m},$$

Amplification factor of the generator, $a_p = 2.5$ (flexible component, Table 11),

Response modification factor $R_p = 2.5$ (vibration isolator, Table 11),

Importance factor $I_p = 1.5$ (life safety component, Table 12),

Weight of the generator, $W_p = 100 \text{ kN}$

The design lateral force on the generator,

$$F_p = \frac{Z}{2} \left(1 + \frac{x}{h} \right) \frac{a_p}{R_p} I_p W_p$$

$$= \frac{0.36}{2} \left(1 + \frac{13.2}{19.2} \right) \frac{2.5}{2.5} (1.5)(100) \text{ kN}$$

$$= 45.6 \text{ kN}$$

$$0.1W_p = 10.0 \text{ kN}$$

Since the generator is mounted on flexible vibration isolator, the design force is doubled i.e.,

$$F_p = 2 \times 45.6 \text{ kN}$$

$$= 91.2 \text{ kN}$$

Shear force resisted by each isolator,

$$V = F_p/4$$

$$= 22.8 \text{ kN}$$

The overturning moment,

$$M_{ot} = (91.2 \text{ kN}) \times (0.8 \text{ m})$$

$$= 73.0 \text{ kN-m}$$

The overturning moment (M_{ot}) is resisted by two vibration isolators on either side. Therefore, tension or compression on each isolator,

$$F_t = \frac{(73.0)}{(1.2)(2)} \text{ kN}$$

$$= 30.4 \text{ kN}$$

Example 9 – Design of a Large Sign Board on a Building

Problem Statement:

A neon sign board is attached to a 5-storey building in Ahmedabad (seismic zone III). It is attached by two anchors at a height 12.0 m and 8.0 m. From the elastic analysis under design seismic load, it is found that the deflections of upper and lower attachments of the sign board are 35.0 mm and 25.0 mm, respectively. Find the design relative displacement.

Solution:

Since sign board is a displacement sensitive nonstructural element, it should be designed for seismic relative displacement.

Height of level x to which upper connection point is attached, $h_x = 12.0$ m

Height of level y to which lower connection point is attached, $h_y = 8.0$ m

Deflection at building level x of structure A due to design seismic load determined by elastic analysis = 35.0 mm

Deflection at building level y of structure A due to design seismic load determined by elastic analysis = 25.0 mm

Response reduction factor of the building $R = 5$ (special RC moment resisting frame, Table 7)

$$\begin{aligned}\delta_{xA} &= 5 \times 35 \\ &= 175.0 \text{ mm}\end{aligned}$$

$$\begin{aligned}\delta_{yA} &= 5 \times 25 \\ &= 125.0 \text{ mm}\end{aligned}$$

$$\begin{aligned}\text{(i) } D_p &= \delta_{xA} - \delta_{yA} \\ &= (175.0 - 125.0) \text{ mm} \\ &= 50.0 \text{ mm}\end{aligned}$$

Design the connections of neon board to accommodate a relative motion of 50 mm.

(ii) Alternatively, assuming that the analysis of building is not possible to assess deflections under seismic loads, one may use the drift limits (this presumes that the building complies with seismic code).

Maximum interstorey drift allowance as per clause 7.11.1 is IS : 1893 is 0.004 times the storey height, i.e.,

$$\frac{\Delta_{aA}}{h_{sx}} = 0.004$$

$$\begin{aligned}D_p &= R(h_x - h_y) \frac{\Delta_{aA}}{h_{sx}} \\ &= 5 (12000.0 - 8000.0)(0.004) \text{ mm} \\ &= 80.0 \text{ mm}\end{aligned}$$

The neon board will be designed to accommodate a relative motion of 80 mm.

Example: 10 Liquefaction Analysis using SPT data

Problem Statement:

The measured SPT resistance and results of sieve analysis for a site in Zone IV are indicated in Table 10.1. The water table is at 6m below ground level. Determine the extent to which liquefaction is expected for 7.5 magnitude earthquake. Estimate the liquefaction potential and resulting settlement expected at this location.

Table 10.1: Result of the Standard penetration Test and Sieve Analysis

Depth (m)	N_{60}	Soil Classification	Percentage fine
0.75	9	Poorly Graded Sand and Silty Sand (SP-SM)	11
3.75	17	Poorly Graded Sand and Silty Sand (SP-SM)	16
6.75	13	Poorly Graded Sand and Silty Sand (SP-SM)	12
9.75	18	Poorly Graded Sand and Silty Sand (SP-SM)	8
12.75	17	Poorly Graded Sand and Silty Sand (SP-SM)	8
15.75	15	Poorly Graded Sand and Silty Sand (SP-SM)	7
18.75	26	Poorly Graded Sand and Silty Sand (SP-SM)	6

Solution:

Site Characterization:

This site consists of loose to dense poorly graded sand to silty sand (SP-SM). The SPT values ranges from 9 to 26. The site is located in zone IV. The peak horizontal ground acceleration value for the site will be taken as 0.24g corresponding to zone factor $Z = 0.24$

Liquefaction Potential of Underlying Soil

Step by step calculation for the depth of 12.75m is given below. Detailed calculations for all the depths are given in Table 10.2. This table provides the factor of safety against liquefaction (FS_{liq}), maximum depth of liquefaction below the ground surface, and the vertical settlement of the soil due to liquefaction (Δ_v).

$$\frac{a_{max}}{g} = 0.24, M_w = 7.5,$$

$$\gamma_{sat} = 18.5 \text{ kN/m}^3, \gamma_w = 9.8 \text{ kN/m}^3$$

Depth of water level below G.L. = 6.00m

Depth at which liquefaction potential is to be

evaluated = 12.75m

Initial stresses:

$$\sigma_v = 12.75 \times 18.5 = 235.9 \text{ kPa}$$

$$u_0 = (12.75 - 6.00) \times 9.8 = 66.2 \text{ kPa}$$

$$\begin{aligned} \sigma'_v &= (\sigma_v - u_0) = 235.9 - 66.2 \\ &= 169.7 \text{ kPa} \end{aligned}$$

Stress reduction factor:

$$r_d = 1 - 0.015z = 1 - 0.015 \times 12.75 = 0.81$$

Critical stress ratio induced by earthquake:

$$a_{max} = 0.24g, M_w = 7.5$$

$$CSR_{eq} = 0.65 \times (a_{maz} / g) \times r_d \times (\sigma_v / \sigma'_v)$$

$$\begin{aligned} CSR_{eq} &= 0.65 \times (0.24) \times 0.81 \times (235.9 / 169.7) \\ &= 0.18 \end{aligned}$$

Correction for SPT (N) value for overburden pressure:

$$(N)_{60} = C_N \times N_{60}$$

$$C_N = 9.79 \left(1 / \sigma'_v\right)^{1/2}$$

$$C_N = 9.79 (1/169.7)^{1/2} = 0.75$$

$$(N)_{60} = 0.75 \times 17 = 13$$

Critical stress ratio resisting liquefaction:

For $(N)_{60} = 13$, fines content of 8%

$$CSR_{7.5} = 0.14 \text{ (Figure F-2)}$$

Corrected Critical Stress Ratio Resisting Liquefaction:

$$CSR_L = CSR_{7.5} k_m k_\alpha k_\sigma$$

k_m = Correction factor for earthquake magnitude other than 7.5 (Figure F-4)

$$= 1.00 \text{ for } M_w = 7.5$$

k_α = Correction factor for initial driving static shear

(Figure F-6)

$$= 1.00, \text{ since no initial static shear}$$

k_σ = Correction factor for stress level larger than 96 kPa (Figure F-5)

$$= 0.88$$

$$CSR_L = 0.14 \times 1 \times 1 \times 0.88 = 0.12$$

Factor of safety against liquefaction:

$$FS_L = CSR_L / CSR_{eq} = 0.12 / 0.18 = 0.67$$

Percentage volumetric strain (%ε)

$$\text{For } CSR_{eqL} = CSR_{eq} / (k_m k_\alpha k_\sigma)$$

$$= 0.18 / (1 \times 1 \times 0.88) = 0.21$$

$$(N_1)_{60} = 13$$

$$\% \epsilon = 2.10 \text{ (from Figure F-8)}$$

Liquefaction induced vertical settlement (ΔV):

(ΔV) = volumetric strain x thickness of liquefiable level

$$= 2.1 \times 3.0 / 100 = 0.063m = 63mm$$

Summary:

Analysis shows that the strata between depths 6m and 19.5m are liable to liquefy. The maximum settlement of the soil due to liquefaction is estimated as 315mm (Table 10.2)

Table 10.2: Liquefaction Analysis: Water Level 6.00 m below GL (Units: Tons and Meters)

Depth	%Fine	σ_v (kPa)	σ'_v (kPa)	N_{60}	C_N	$(N)_{60}$	r_d	CSR_{eq}	CSR_{eqL}	$CSR_{7.5}$	CSR_L	FS_L	$\% \epsilon$	ΔV
0.75	11.00	13.9	13.9	9.00	2.00	18	0.99	0.15	0.14	0.22	0.25	1.67	-	-
3.75	16.00	69.4	69.4	17.00	1.18	20	0.94	0.15	0.14	0.32	0.34	2.27	-	-
6.75	12.00	124.9	117.5	13.00	0.90	12	0.90	0.15	0.15	0.13	0.13	0.86	2.30	0.069
9.75	8.00	180.4	143.6	18.00	0.82	15	0.85	0.17	0.18	0.16	0.15	0.88	1.90	0.057
12.75	8.00	235.9	169.7	17.00	0.75	13	0.81	0.18	0.20	0.14	0.12	0.67	2.10	0.063
15.75	7.00	291.4	195.8	15.00	0.70	10	0.76	0.18	0.21	0.11	0.09	0.50	2.50	0.075
18.75	6.00	346.9	221.9	26.00	0.66	17	0.72	0.18	0.22	0.18	0.15	0.83	1.70	0.051
Total Δ														0.315

Example: 11 Liquefaction Analysis using CPT data

Problem Statement:

Prepare a plot of factors of safety against liquefaction versus depth. The results of the cone penetration test (CPT) of 20m thick layer in Zone V are indicated in Table 11.1. Assume the water table to be at a depth of 2.35 m, the unit weight of the soil to be 18 kN/m^3 and the magnitude of 7.5.

Table 11.1: Result of the Cone penetration Test

Depth (m)	\bar{q}_c	\bar{f}_s	Depth (m)	\bar{q}_c	\bar{f}_s	Depth (m)	\bar{q}_c	\bar{f}_s
0.50	144.31	0.652	7.50	45.46	0.132	14.50	46.60	0.161
1.00	95.49	0.602	8.00	39.39	0.135	15.00	46.77	0.155
1.50	39.28	0.281	8.50	36.68	0.099	15.50	47.58	0.184
2.00	20.62	0.219	9.00	45.30	0.129	16.00	41.99	0.130
2.50	150.93	1.027	9.50	51.05	0.185	16.50	48.94	0.329
3.00	55.50	0.595	10.00	46.39	0.193	17.00	56.69	0.184
3.50	10.74	0.359	10.50	58.05	0.248	17.50	112.90	0.392
4.00	9.11	0.144	11.00	48.94	0.159	18.00	104.49	0.346
4.50	33.69	0.297	11.50	63.75	0.218	18.50	77.75	0.256
5.00	70.69	0.357	12.00	53.93	0.193	19.00	91.58	0.282
5.50	49.70	0.235	12.50	53.60	0.231	19.50	74.16	0.217
6.00	51.43	0.233	13.00	62.39	0.275	20.00	115.02	0.375
6.50	64.94	0.291	13.50	54.58	0.208			
7.00	57.24	0.181	14.00	52.08	0.173			

Solution:

Liquefaction Potential of Underlying Soil

Step by step calculation for the depth of 4.5m is given below. Detailed calculations are given in Table 11.2. This table provides the factor of safety against liquefaction (FS_{liq}).

The site is located in zone V. The peak horizontal ground acceleration value for the site will be taken as 0.36g corresponding to zone factor $Z = 0.36$

$$a_{max}/g = 0.36, M_w = 7.5,$$

$$\gamma_{sat} = 18 \text{ kN/m}^3, \gamma_w = 9.8 \text{ kN/m}^3$$

Depth of water level below G.L. = 2.35m

Depth at which liquefaction potential is to be evaluated = 4.5m

Initial stresses:

$$\sigma_v = 4.5 \times 18 = 81.00 \text{ kPa}$$

$$u_0 = (4.5 - 2.35) \times 9.8 = 21.07 \text{ kPa}$$

$$\sigma'_v = (\sigma_v - u_0) = 81 - 21.07 = 59.93 \text{ kPa}$$

Stress reduction factor:

$$r_d = 1 - 0.000765 z$$

$$= 1 - 0.000765 \times 4.5 = 0.997$$

Critical stress ratio induced by earthquake:

$$CSR_{eq} = 0.65 \times (a_{maz} / g) \times r_d \times (\sigma_v / \sigma'_v)$$

$$CSR_{eq} = 0.65 \times (0.36) \times 0.997 \times (81 / 59.93)$$

$$= 0.32$$

Corrected Critical Stress Ratio Resisting Liquefaction:

$$CSR_L = CSR_{eq} k_m k_\alpha k_\sigma$$

k_m = Correction factor for earthquake magnitude other than 7.5
(Figure F-4)

$$= 1.00 \text{ for } M_w = 7.5$$

k_α = Correction factor for initial driving static shear

(Figure F-6)

$$= 1.00, \text{ since no initial static shear}$$

k_σ = Correction factor for stress level larger than 96 kPa
(Figure F-5)

$$= 1.00$$

$$CSR_L = 0.32 \times 1 \times 1 \times 1 = 0.32$$

Correction factor for grain characteristics:

$$K_c = 1.0 \quad \text{for } I_c \leq 1.64 \text{ and}$$

$$K_c = -0.403I_c^4 + 5.581I_c^3 - 21.63I_c^2$$

$$\vdots + 33.75I_c - 17.88 \quad \text{for } I_c > 1.64$$

The soil behavior type index, I_c , is given by

$$I_c = \sqrt{(3.47 - \log Q)^2 + (1.22 + \log F)^2}$$

$$I_c = \sqrt{(3.47 - \log 42.19)^2 + (1.22 + \log 0.903)^2}$$

$$= 2.19$$

Where,

$$F = f / (q_c - \sigma_v) \times 100$$

$$F = [29.7 / (3369 - 81)] \times 100 = 0.903 \text{ and}$$

$$Q = [(q_c - \sigma_v) / P_a] (P_a / \sigma'_v)^n$$

$$Q = [(3369 - 81) / 101.35] \times (101.35 / 59.93)^{0.5}$$

$$= 42.19$$

$$K_c = -0.403(2.19)^4 + 5.581(2.19)^3 - 21.63(2.19)^2$$

$$\vdots + 33.75(2.19) - 17.88 = 1.64$$

Normalized Cone Tip Resistance:

$$(q_{c1N})_{cs} = K_c (P_a / \sigma'_v)^n (q_c / P_a)$$

$$(q_{c1N})_{cs} = 1.64 (101.35 / 59.93)^{0.5} (3369 / 101.35)$$

$$= 70.77$$

Factor of safety against liquefaction:

$$\text{For } (q_{c1N})_{cs} = 70.77,$$

$$CRR = 0.11 \text{ (Figure F-6)}$$

$$FS_{liq} = CRR / CSR_L$$

$$FS_{liq} = 0.11 / 0.32 = 0.34$$

Summary:

Analysis shows that the strata between depths 0-1m are liable to liquefy under earthquake shaking corresponding to peak ground acceleration of 0.36g. The plot for depth verses factor of safety is shown in Figure 11.1

Table 11.2: Liquefaction Analysis: Water Level 2.35 m below GL (Units: kN and Meters)

Depth	σ_v	σ'_v	r_d	qc (kPa)	fs (kPa)	CSR _{eq}	CSR _L	F	Q	Ic	Kc	(qc1N)cs	CRR	FS _{liq}
0.50	9.00	9.00	1.00	14431	65.20	0.23	0.23	0.45	241.91	1.40	1.00	242.06	100.00	434.78
1.00	18.00	18.00	1.00	9549	60.20	0.23	0.23	0.63	159.87	1.63	1.00	160.17	100.00	434.78
1.50	27.00	27.00	1.00	3928	28.10	0.23	0.23	0.72	65.43	1.97	1.27	83.53	0.13	0.57
2.00	36.00	36.00	1.00	2062	21.90	0.23	0.23	1.08	33.54	2.31	1.99	68.04	0.11	0.47
2.50	45.00	43.53	1.00	15093	102.70	0.24	0.24	0.68	226.55	1.53	1.00	227.23	100.00	416.67
3.00	54.00	47.63	1.00	5550	59.50	0.26	0.26	1.08	79.10	2.01	1.31	105.02	0.19	0.73
3.50	63.00	51.73	1.00	1074	35.90	0.28	0.28	3.55	13.96	2.92	5.92	87.81	0.14	0.50
4.00	72.00	55.83	1.00	911	14.40	0.30	0.30	1.72	11.15	2.83	5.01	60.64	0.10	0.33
4.50	81.00	59.93	1.00	3369	29.70	0.32	0.32	0.90	42.19	2.19	1.64	70.77	0.11	0.34
5.00	90.00	64.03	1.00	7069	35.70	0.33	0.33	0.51	86.63	1.79	1.10	96.60	0.16	0.48
5.50	99.00	68.13	1.00	4970	23.50	0.34	0.34	0.48	58.62	1.93	1.22	72.68	0.12	0.35
6.00	108.00	72.23	1.00	5143	23.30	0.35	0.35	0.46	58.85	1.92	1.21	72.45	0.12	0.34
6.50	117.00	76.33	1.00	6494	29.10	0.36	0.36	0.46	72.50	1.83	1.13	83.61	0.13	0.36
7.00	126.00	80.43	0.99	5724	18.10	0.36	0.36	0.32	62.00	1.83	1.13	71.56	0.11	0.31
7.50	135.00	84.53	0.99	4546	13.20	0.37	0.37	0.30	47.66	1.92	1.21	59.46	0.10	0.27
8.00	144.00	88.63	0.99	3939	13.50	0.38	0.38	0.36	40.04	2.02	1.33	55.18	0.10	0.26
8.50	153.00	92.73	0.99	3668	9.90	0.38	0.38	0.28	36.26	2.02	1.33	50.45	0.09	0.24
9.00	162.00	96.83	0.99	4530	12.90	0.39	0.39	0.30	44.09	1.95	1.24	56.79	0.10	0.26
9.50	171.00	100.93	0.75	5105	18.50	0.30	0.30	0.37	48.78	1.95	1.24	62.62	0.10	0.33
10.00	180.00	105.03	0.73	4639	19.30	0.29	0.29	0.43	43.22	2.02	1.33	59.94	0.10	0.34
10.50	189.00	109.13	0.72	5805	24.80	0.29	0.29	0.44	53.40	1.95	1.23	68.16	0.11	0.38
11.00	198.00	113.23	0.71	4894	15.90	0.29	0.29	0.34	43.84	1.98	1.27	58.01	0.10	0.34
11.50	207.00	117.33	0.69	6375	21.80	0.29	0.29	0.35	56.56	1.88	1.17	68.51	0.11	0.38
12.00	216.00	121.43	0.68	5393	19.30	0.28	0.28	0.37	46.67	1.97	1.26	61.23	0.10	0.36
12.50	225.00	125.53	0.67	5360	23.10	0.28	0.28	0.45	45.53	2.01	1.31	62.48	0.10	0.36
13.00	234.00	129.63	0.65	6239	27.50	0.28	0.28	0.46	52.39	1.96	1.25	68.09	0.11	0.39
13.50	243.00	133.73	0.64	5458	20.80	0.27	0.27	0.40	44.79	2.00	1.29	60.67	0.10	0.37
14.00	252.00	137.83	0.63	5208	17.30	0.27	0.27	0.35	41.93	2.00	1.30	57.21	0.10	0.37
14.50	261.00	141.93	0.61	4660	16.10	0.26	0.26	0.37	36.68	2.06	1.39	53.90	0.09	0.35
15.00	270.00	146.03	0.60	4677	15.50	0.26	0.26	0.35	36.23	2.06	1.38	53.24	0.09	0.35
15.50	279.00	150.13	0.59	4758	18.40	0.25	0.25	0.41	36.31	2.08	1.43	55.02	0.10	0.40
16.00	288.00	154.23	0.57	4199	13.00	0.25	0.25	0.33	31.28	2.11	1.47	49.44	0.09	0.36
16.50	297.00	158.33	0.56	4894	32.90	0.25	0.25	0.72	36.29	2.19	1.65	63.63	0.10	0.40
17.00	306.00	162.43	0.55	5669	18.40	0.24	0.24	0.34	41.80	2.00	1.30	57.28	0.10	0.42
17.50	315.00	166.53	0.53	11290	39.20	0.24	0.24	0.36	84.48	1.73	1.06	91.71	0.15	0.63
18.00	324.00	170.63	0.52	10449	34.60	0.23	0.23	0.34	76.99	1.75	1.07	85.35	0.14	0.61
18.50	333.00	174.73	0.51	7775	25.60	0.23	0.23	0.34	55.92	1.88	1.17	68.46	0.11	0.48
19.00	342.00	178.83	0.49	9158	28.20	0.22	0.22	0.32	65.48	1.81	1.11	75.57	0.12	0.55
19.50	351.00	182.93	0.48	7416	21.70	0.22	0.22	0.31	51.89	1.89	1.18	64.35	0.10	0.45
20.00	360.00	187.03	0.47	11502	37.50	0.21	0.21	0.34	80.93	1.73	1.06	88.47	0.14	0.67

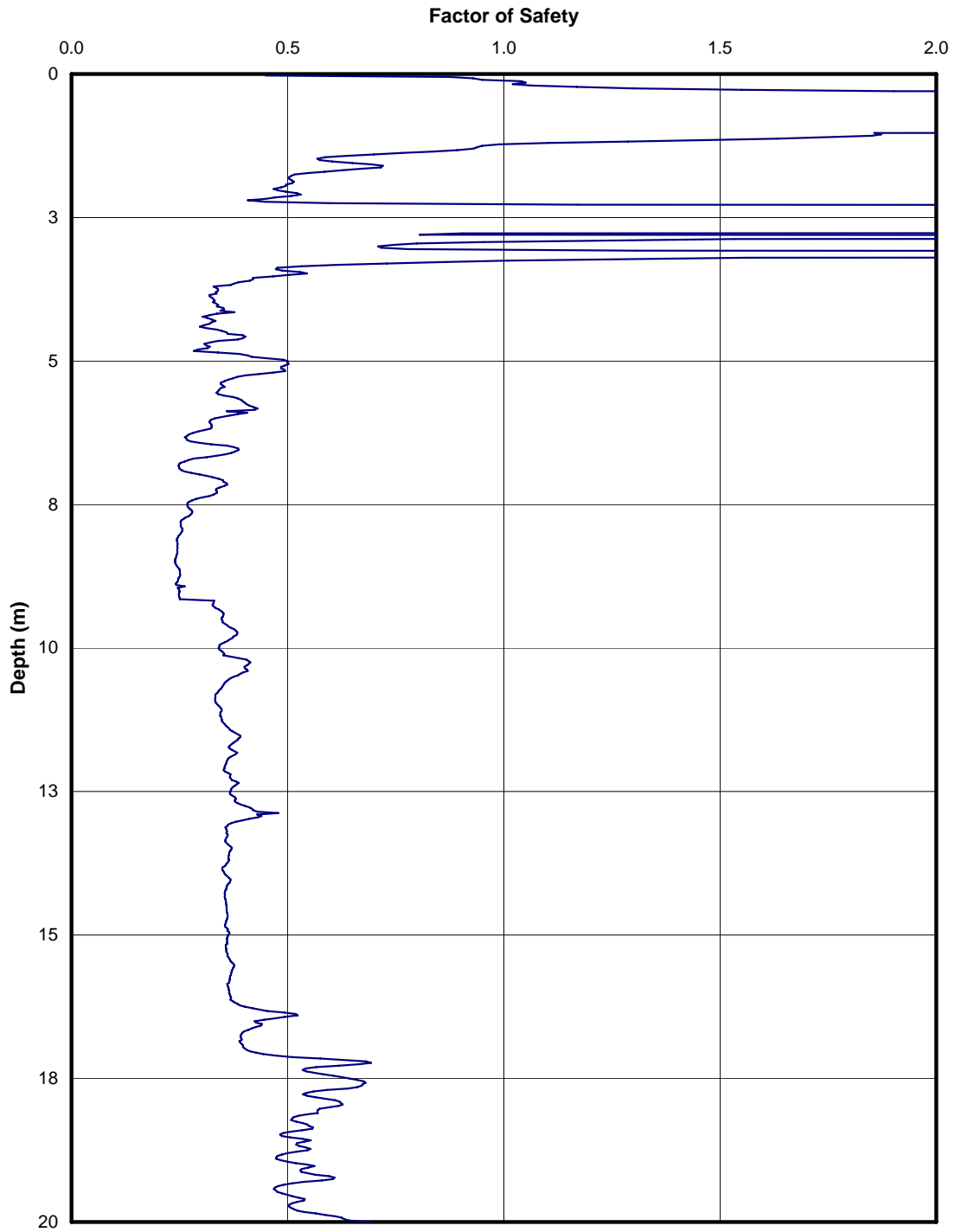

Figure 11.1: Factor of Safety against Liquefaction