

LIMITED TENDER ENQUIRY

FOR

SUPPLY & INSTALLATION OF

LABORATORY FURNITURE'S

AT

IIT Rajasthan

Dated: 04th November 2010

Tender No.: IITJ/TEN/LAB/FUR/2010-11/28

Last Date of submission: 14 November 2010



Indian Institute Technology, Rajasthan
Camp Office: MBM Engineering College, Jodhpur – 342011, Rajasthan
Tel.: 0291-2516823, 2516872, email: iitj@iitk.ac.in

Indian Institute of Technology (IIT), Rajasthan, Jodhpur invites tenders for supply, erection, installation and commissioning of Laboratory Furniture's at various Laboratories of the Institute at Academic block – I & II as per specifications given in the Schedule attached to the Tender form annexed hereto. All offers should be made in the English and should be written in both figures and words. The relevant brochure may also be enclosed. Tender forms can be downloaded from the website (http://www.iitk.ac.in/iitj/tender_notice.htm) of the institute.

The bidders are requested to read the tender document carefully and ensure compliance with all instructions herein. Non-compliance with instructions in this document may disqualify the bidders from the tender exercise.

The Director, IIT Rajasthan, Jodhpur reserves the right to select certain items (in single or multiple units) and reject the others or all mentioned in the Schedule. The Director, IIT Rajasthan, also reserves the right to revise or alter the specifications of the furniture before acceptance of any tender.

Incomplete tenders, amendments and additions to tender after opening or late tenders are liable to be ignored, and rejected.

The bidders are requested to submit Technical Bid and Price Bid in separate sealed covers as follows:

- (i) Technical Bid containing information regarding business turnover, experience and other details of the firm to judge the suitability of the bidder.
- (ii) Price bid containing prices of the various products clearly mentioning all charges and taxes as may be applicable.

The tender shall be submitted in a sealed envelope bearing the following reference on the top left hand corner: "Tender No.: IITJ/TEN/LAB/FUR/2010-11/28", latest by **15 November 2010, 10:00** hrs and addressed to:

"The Director,

IIT Rajasthan,

Camp Office: MBM Engineering College, Jodhpur – 342011, Rajasthan"

All tender documents should be sent through courier, speed post or registered post. All tender documents received after this specified date and time shall not be considered.

The Technical bid will be opened on **15 November 2010 at 3:00 pm** in the Conference Hall of the Institute in the presence of the bidders who are present at the time. Price bids of only those bidders will be opened whose technical bids are found suitable by the committee appointed for the purpose. Date and time of opening of price bids will be decided after technical bids have been evaluated by the committee. Information in this regard will be posted on Institute's web site / Notice board. No separate information shall be given to individual bidders.

1. Site Visit:

- Bidders can visit the site for getting exact details before this date. The bidders are requested to visit the institute and meet the following personnel to finalize/decide on the specifications of furnitures for each lab:

Dr. Laltu Chandra : Heat and Fluid Dynamics Lab (dr_laltu_chandra@yahoo.com, Phone – 0291- 2449056)

Dr. Srirupa Chatterjee: Language Lab (srirupa@iitk.ac.in, Phone: 0291-2449064)

Dr. Akhilesh Mohan: Microwaves and Electromagnetics Lab (amohan1232001@gmail.com, Phone: 0291-2449039)

Dr. Sandeep Yadav: Instrumentation Lab (sandeepy@iitk.ac.in, Phone: 0291-2449051)

Dr. Swagat Kumar: Computer Centre (swagat.kumar@gmail.com, Phone: 0291-2449033)

Pre-bid meeting would take place on the same day among all the present vendors to freeze the specifications.

2. Tender Cost:

- A Demand draft of Rs. 500/- (Rupees Five Hundred only) towards non-refundable tender fee drawn in favour of “Director, IIT Rajasthan” payable at Jodhpur should accompany with the Technical bid document.

3. Earnest Money Deposit (EMD):

- A Demand draft of **Rs. 50, 000/- (Rupees Fifty Thousand only)** towards EMD drawn in favour of “Director, IIT Rajasthan” payable at Jodhpur should accompany with the Technical bid document

4. Pre – Qualification Criteria:

- a. Bidders should be the OEM / Authorized Partner / Service provider of the OEM, for Partner/ Service Providers, Letter of Authorization from OEM on the same and specific to the tender should be enclosed.
- b. The participant i.e. manufacturers/companies having own manufacturing units/infrastructure or their authorized dealers should have completed the works of **similar nature** exceeding Rs. 3 crore each. This should be certified by an officer not below the rank of Executive Engineer / Project Manager or equivalent.
- c. The bidder must not be blacklisted anywhere in India or abroad by any organization whatsoever. A certificate or undertaking to this effect must be submitted.
- d. The bidder should submit copies of Income Tax returns filed for previous three financial years proceeding with current financial year.
- e. Manufacturer should be an ISO 9001:2000 , ISO 14001:2004, BS OHSAS 18001:2007 certified company.
- f. The manufacturer should be a member of BIFMA International (Business and Institutional Furniture Manufacturers Association) and member of India Green Building Council (IGBC)

under the category of “Manufacturing/Product Sales”.

- g. Manufacturer’s products should have an impact on LEED (Leadership in Energy & Environmental Design) Credits. Manufacturer should have a powder coating plant/paint shop in its facility.
- h. Must have own Powder coating application unit phosphating & chromating process that takes place in 9 Tank Treatment sequence wise, as follows:
 - i. Tank 1 - Degreasing
 - ii. Tank 2 - Water Swill
 - iii. Tank 3 - Derusting
 - iv. Tank 4 - Water Swill
 - v. Tank 5 - Activator
 - vi. Tank 6 - Phosphating
 - vii. Tank 7 - Water Swill
 - viii. Tank 8 - Passivation Solution
 - ix. Tank 9 – Water Drying Oven
- i. In house quality assurance lab reliability testing in line with BIFMA/UL/BIS.
- j. The participant should have had average annual financial turn over (gross) of Rs 100 Crores on similar works during the immediate last three consecutive financial years. This should be duly audited by a Chartered Accountant. Year in which no turnover is shown would also be considered for working out the average.
- k. Must have following in house production equipments for carrying out the modular furniture work

S. No	Name of Equipment
1	CNC ROUTER MACHINE
2	PEDESTAL ROUTER
3	SPINDLE MOULDING MACHINE
4	POSTFORMING MACHINE
5	EDGE BANDING MACHINE
6	DUST PARTICLE MACHINE
7	HOT PRESS
8	CONCAVE FORMING DEVICE
9	FELDER SHAPER MACHINE
10	DUST EXTRACTION MACHINE
11	UNITE PRESS CONTRA
12	SWORD BRUSH CLEANING

13	P-FOL GLUE APPLICATOR
14	STILLER
15	PANEL SAW

o) Bidder has to produce Mock up of the items as asked for the evaluation of quality and conformance to the technical standards, when called.

5. Prices:

- The Prices quoted should be inclusive of all taxes or duties, packing, forwarding, freight, insurance, delivery and commissioning etc. at destination site (IIT Rajasthan, Jodhpur). IIT Rajasthan is registered with DSIR, Govt. of India (*Custom duty Notification No. 51/96-custom dt: 23 July, 1996 and Central Excise duty Notification No. 10/97-Central Excise dt: 1 March, 1997*) and is, therefore, exempted from Custom / Excise Duty. Exemption Certificate of the same shall be issued by IIT Rajasthan.

6. Validity:

- The bid should be valid for acceptance up to a period of 120 Days. The Bidders should be ready to extend the validity, if required.

7. Delivery:

- All the goods ordered shall be delivered & Installed within 6 weeks from the date of receiving the purchase order at the above destination.

8. Warranty Declaration:

- Bidders must give the comprehensive on-site three years warranty from the date of installation of Furniture's against any manufacturing defects and also give the warranty declaration that everything to be supplied by us hereunder shall be free from all defects and faults in material, workmanship and shall be of the highest quality and material of the type ordered, shall be in full conformity with the specification.
- Any deviation in the material, and the specifications from the accepted terms may liable to be rejected and the bidders need to supply all the goods in the specified form to the satisfaction / specifications specified in the order / contract and demonstrate at the their own cost. ***The payments shall be made only after receiving the materials in the required format and quality to the satisfaction of the Institute Authorities.***

8. Terms of Payment:

- No advance payment will be made for Indigenous purchase.
- 70% Payment of the total order value shall be released by the Institute only after receipt of materials and balance 30% will be released after complete installation of the Furniture's in good condition.

- In case of Import supplies payment will be made through 100% irrevocable Letter of Credit or by TT.

9. Tender expenses and documents:

- All costs incurred by the bidder in the preparation of the tender shall be at the entire expense of the bidder.

10. Tender Evaluation Criteria:

- Bids will be evaluated on the basis of the terms & conditions already incorporated in the tender document, based on which tenders have been received and the terms, conditions etc. mentioned by the bidders in their tenders. No new condition will be brought in while scrutinizing and evaluating the tenders.
- The Committee will examine all the bids to determine whether they are complete, whether any computational errors have been made, whether required sureties have been furnished, whether the documents have been properly signed stamped and whether the Tenders are generally in order.
- Prior to the detailed evaluation of Price Tenders, the committee will determine the substantial responsiveness of each bidder to the tender document. The substantially responsive bidder is one, which accepts all the terms and conditions of the tender documents without material deviations. Deviations from, or objections or reservations to critical provisions such as those concerning EMD, Delivery, Warranty, Taxes & Duties, Force Majeure and other terms & condition of the tender. The committee determination of a Tender's responsiveness is to be based on the contents of the tender itself without recourse to extrinsic evidence.
- If a Tender is not substantially responsive, it will be rejected by the Purchaser and cannot subsequently be made responsive by the bidders by correction of the nonconformity.
- The tenders will be scrutinized to determine whether they are complete and meet the essential and important requirements, conditions etc. as prescribed in the tender document. The tenders, which do not meet the basic requirements, are liable to be treated as non – responsive and will be summarily ignored.

11. Award of Contract:

- Committee reserves the right to accept any tender and to reject any or all tenders.
- The Committee reserves the right to accept in part or in full any tender or reject any or more tender(s) without assigning any reason or to cancel the tendering process and reject all tenders at any time prior to award of contract, without incurring any liability, whatsoever to the affected bidder or bidders.
- The committee will scrutiny the bids and tender evaluation will determine to its satisfaction whether the bidder, whose bid has been determined as the lowest evaluated responsive tender is eligible, qualified and capable in all respects to perform the contract satisfactorily. If, there is more than one schedule in the List of Requirements, then, such determination will be made

separately for each schedule.

- The contract will be awarded to the lowest evaluated responsive bidder decided by the committee.
- The contract for bulk order would be awarded subject to the approval of the sample submitted the finally selected L1 bidder.
- The committee reserves its right to split up the total order into several smaller orders – one for each lab. In that case, the L1 bidder will be decided for each lab separately.

12. Liquidated Damages (Late Delivery):

- The furniture should be delivered and installed in specified period as specified in the purchase order and be ready for use within 4 weeks of the issue of purchase order unless otherwise prescribed. If the bidder fails to deliver and place any or all the furniture or perform the service by the specified date, penalty at the rate of 1% per week of the total order value subject to maximum of 10% of total order value.

13. Force Majeure:

- Any delay due to Force Majeure will not be attributable to the bidder.

14. Arbitration and Laws:

- Except where otherwise provided for in the contract, all questions and disputes relating to interpretation and application of the provisions of the contract shall be settled mutually within thirty (30 only) days (or such longer period as may be mutually agreed upon) from the date that either party notifies in writing that such dispute or disagreement exists, under the Rules of Indian Arbitration and Conciliation Act, 1996. The venue of Arbitration shall be Jodhpur, Rajasthan, India. The arbitration resolution shall be final and binding upon the parties and Judgment may be entered thereon, upon the application of either party, by Jodhpur court having jurisdiction. The Indian laws shall govern this contract.

15. Return of EMD:

- The earnest money of the successful bidder will be deposit as security money and return to them without any interest after completing the successful contract.
- The earnest money of unsuccessful bidders will be returned to them without any interest with in thirty day after awarding the contact.

BID PARTICULARS

1. Name of the Supplier :

2. Address of the Supplier :

3. Address of the Show Room :

4. Availability of demonstration of Goods : Yes / No

5. EMD enclosed : Yes / No if Yes
D.D. No. _____ Bank _____ Amount _____

6. Name and address of the Officer to whom all references shall be made regarding this tender enquiry.

Name :
Address :
Telephone No. :
Fax No. :
Mobile No :
e-mail :
Web :

Specification & Design

Annexure-1

1. Heat Transfer and Fluid Dynamics Lab:

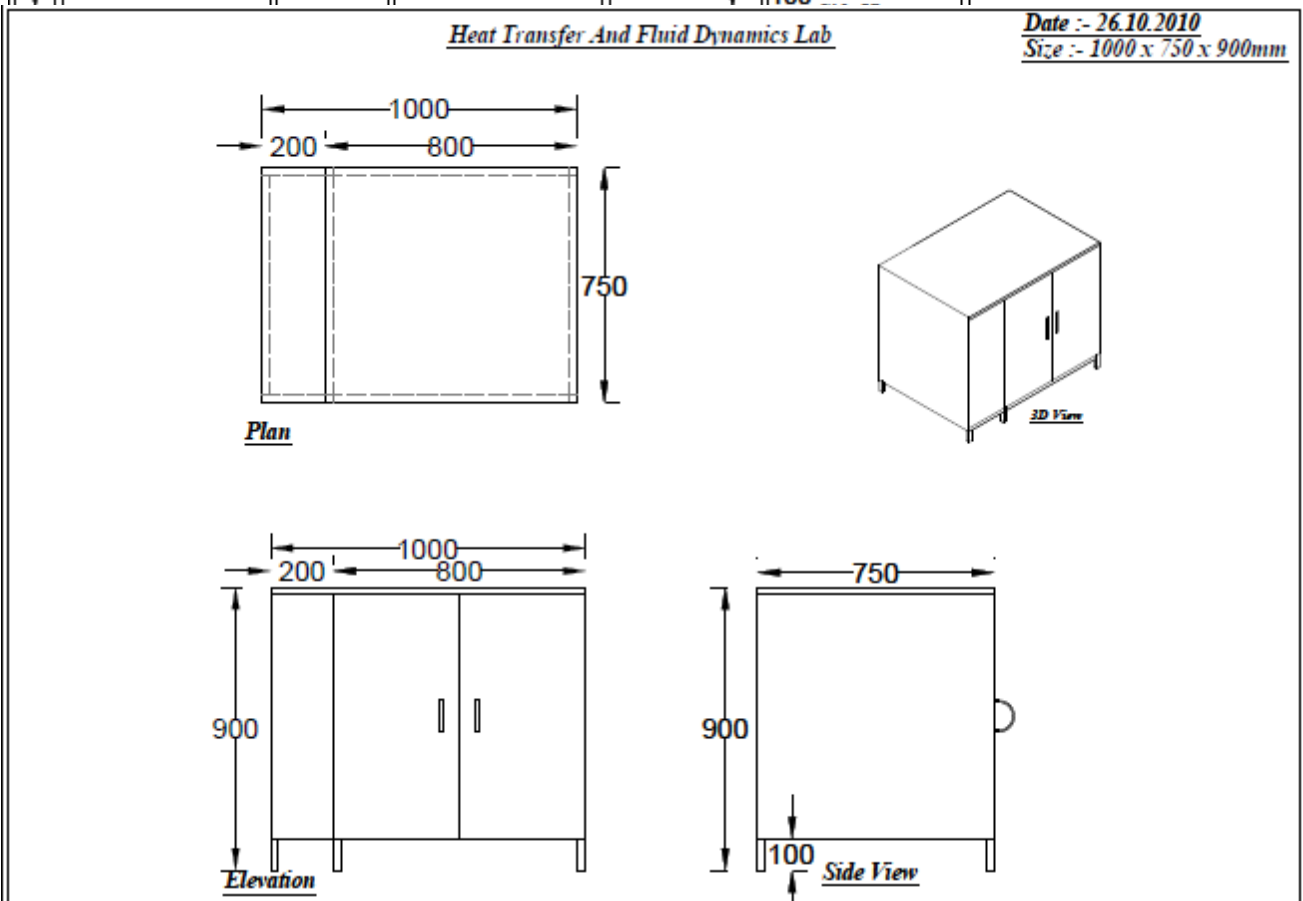
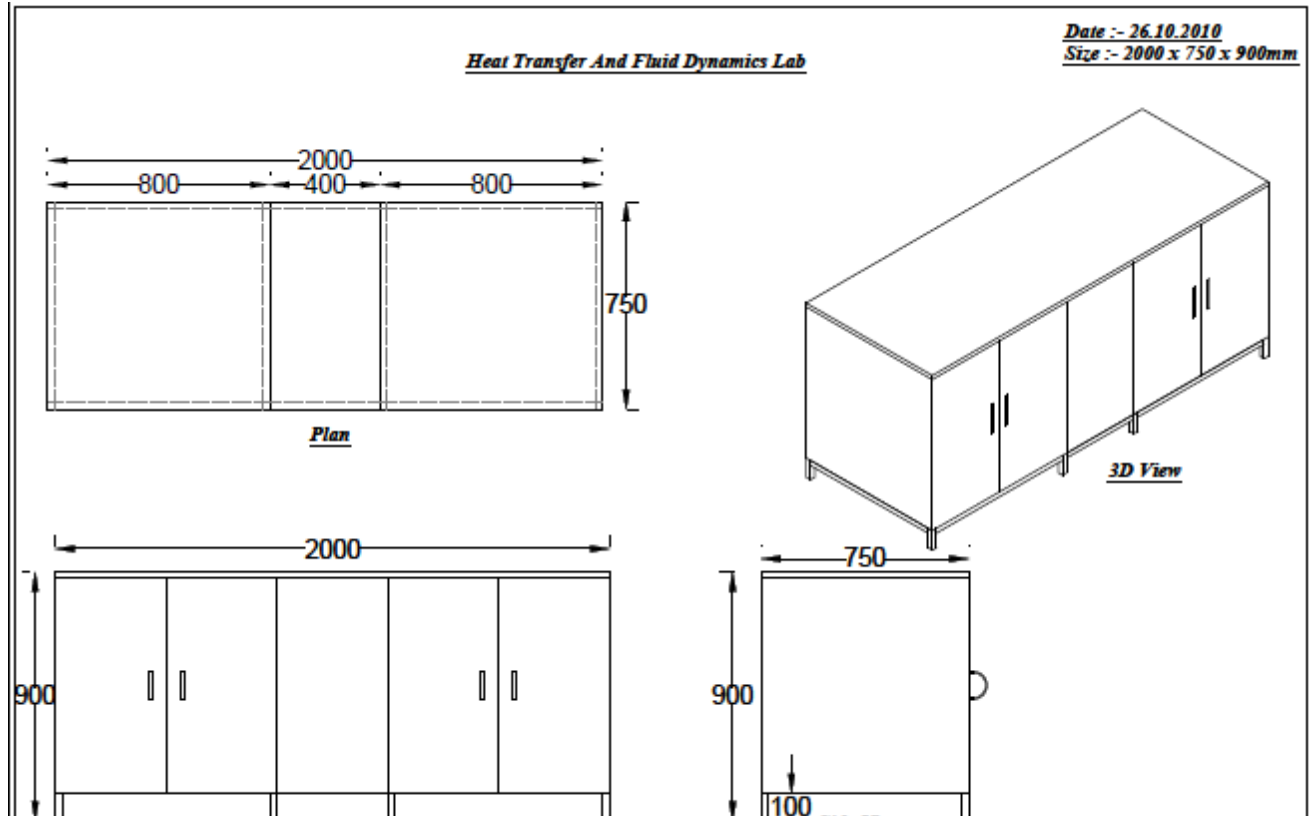

Remarks on the table

cold rolled steel finished with durable epoxy polyester powder coating

Temperature resistant top surface ~ 200 °C

Strength ~ 200 kg/m²

Anti-vibration

Electric Socket 20 A upto 400 V

Black Jet Granite Top - 20 mm with 8 mm ply backing

Annexure – 2

2. Electromagnetics and Microwaves Lab:

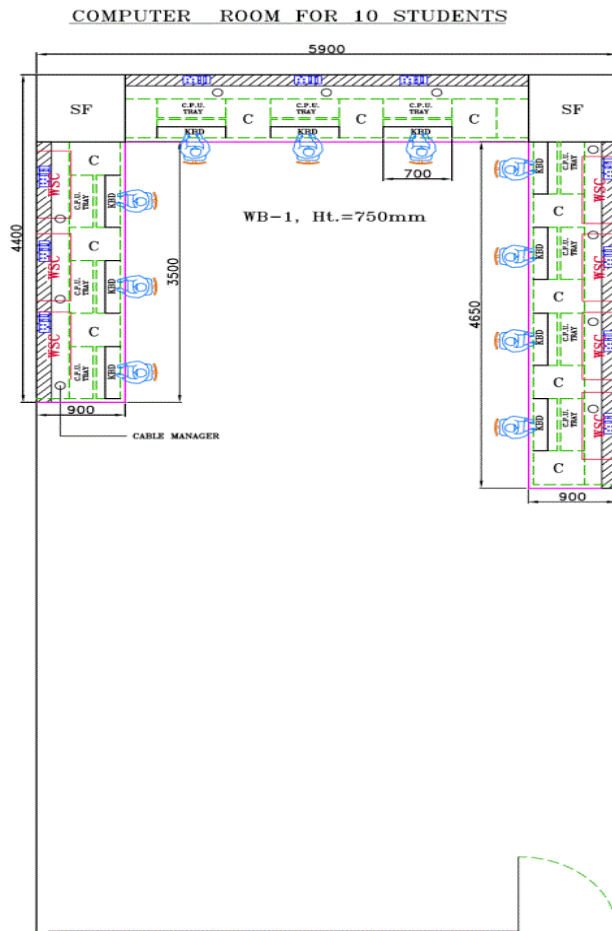

DESCRIPTION:

QTY

C - 1DRAWER 1 SHUTTER MODULE 450 MM,	10 NOS.
WB - WALL BENCH	01 NO.
SF - STRUCTURE FRAME	02 NOS.
KBD - KEY BOARD DRAWER	10 NOS.
C.P.U. TRAY	10 NOS.
WSC - WALL STORAGE CUPBOARD	07 NOS.
▨ - ELECTRIC DUCT	03 NOS.
Ⓜ - 3 MODULE ELECTRIC SOCKET	10 NOS.

NOTE :- ALL DIMENSIONS ARE IN MM

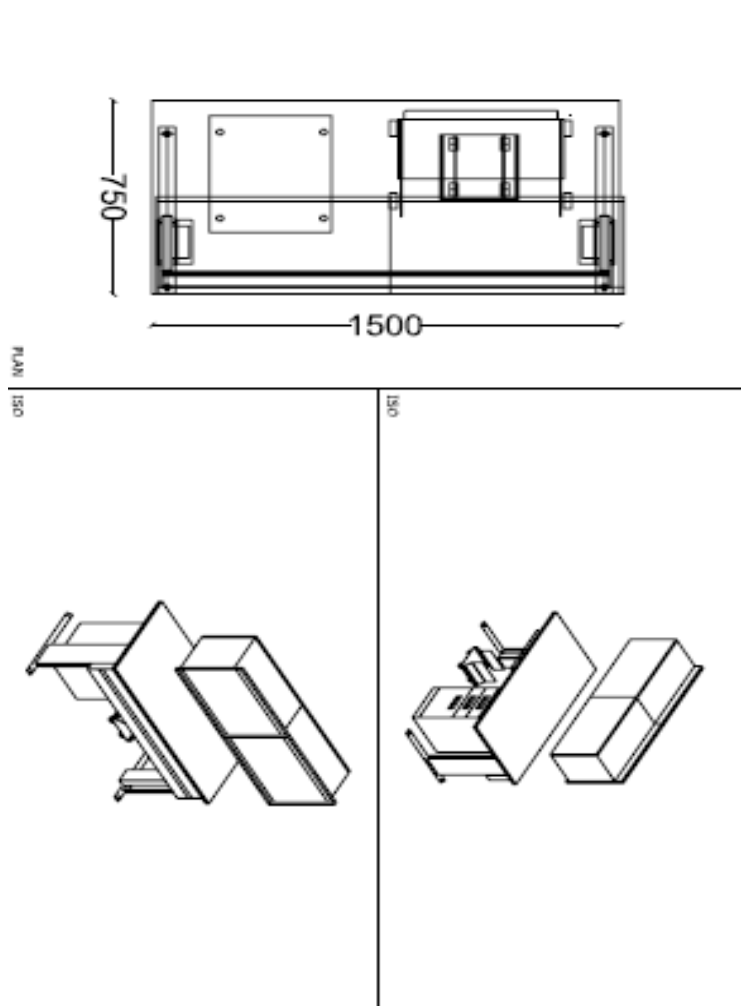

1. Size: 1500 x 750 mm
2. Electrical and Data Slots on below WTOP & Skirting Level
3. Keyboard Tray
4. CPU Trolley
5. PEDESTAL Unit: 400 x 460 x 621
6. Table Top Made of 25 mm Thick Pre-laminated particle board with PVC Lipping
7. Wall Mounted Over-head cabinet of size: 750 x 525 H

DESCRIPTION:

- WB - WALL BENCH
- CPU TRAY
- ▨ - ELECTRIC DUCT
- ⊞ - ELECTRIC POINT

QTY

- 10 NOS.
- 30 NOS.
- 30 NOS.
- 90 NOS.

NOTE - ALL DIMENSIONS ARE IN MM

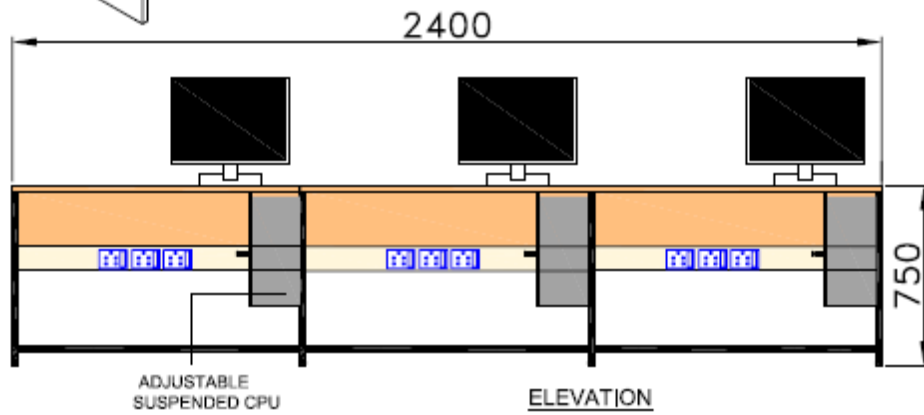
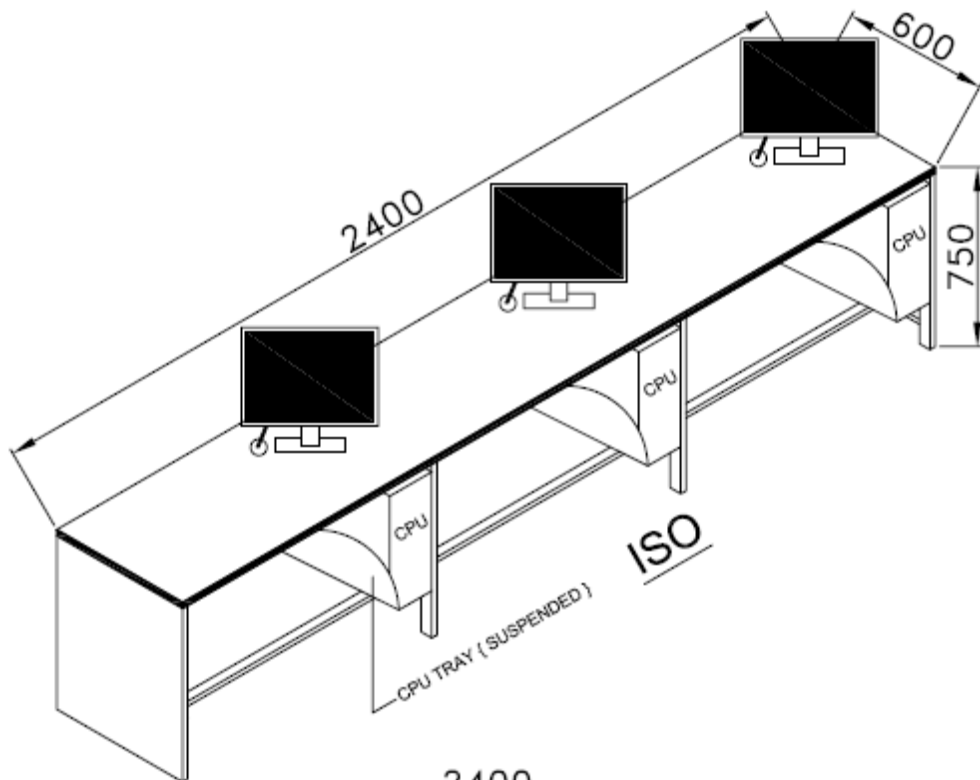

ADJUSTABLE
SUSPENDED CPU





ELEVATION

NOTE - ALL DIMENSIONS ARE IN MM

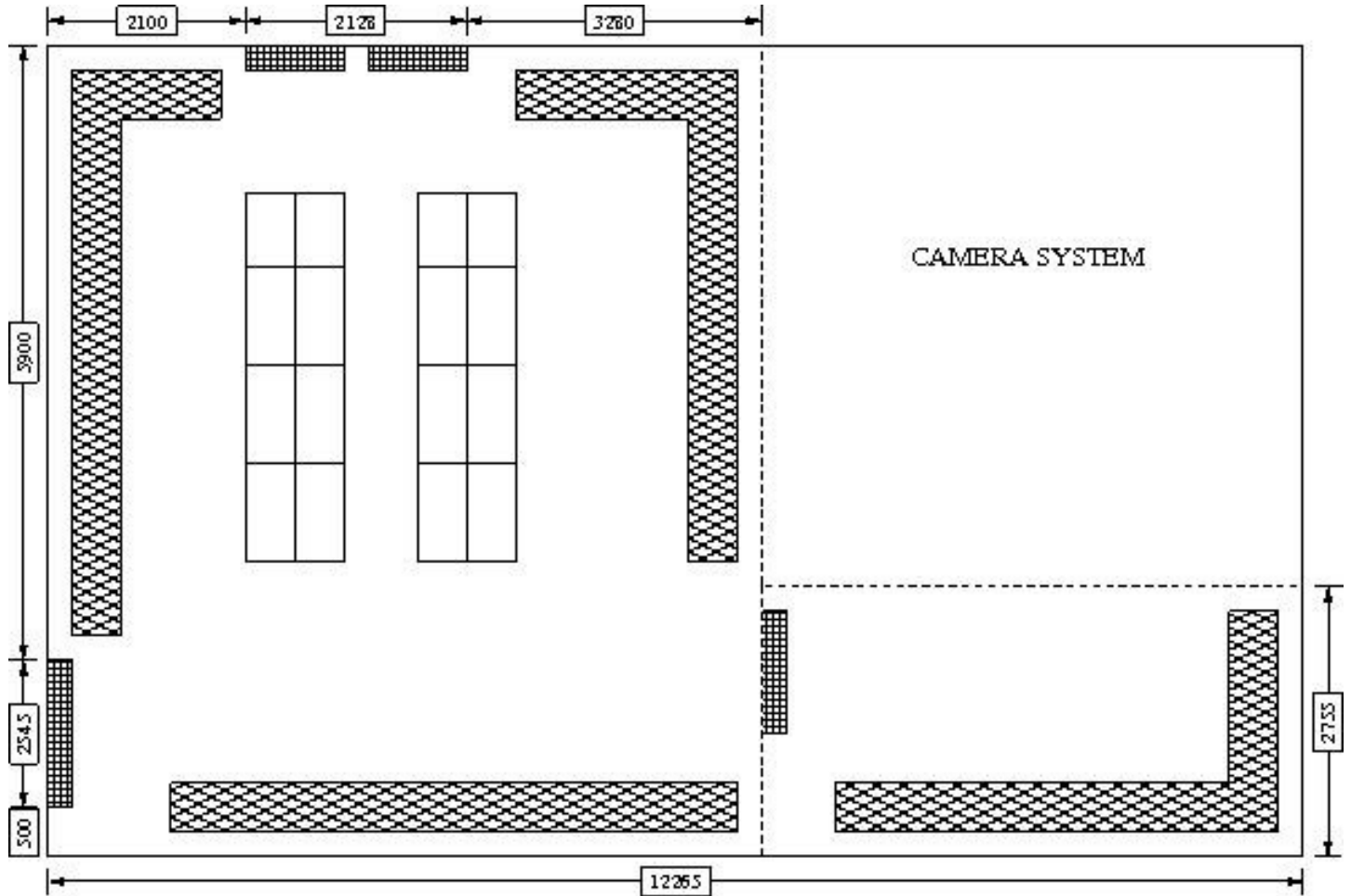
Annexure – 4

4. Robotics and Instrumentation Lab:



-  Door
-  Table (Desk)
-  Glass Partition
-  Wall
-  Two-sided workstation

All measurements are in mm.

Robotics and Instrumentation Lab (Dr. Sandeep Yadav)

ISO view of Two Sided Work-stations for Instrumentation Lab:

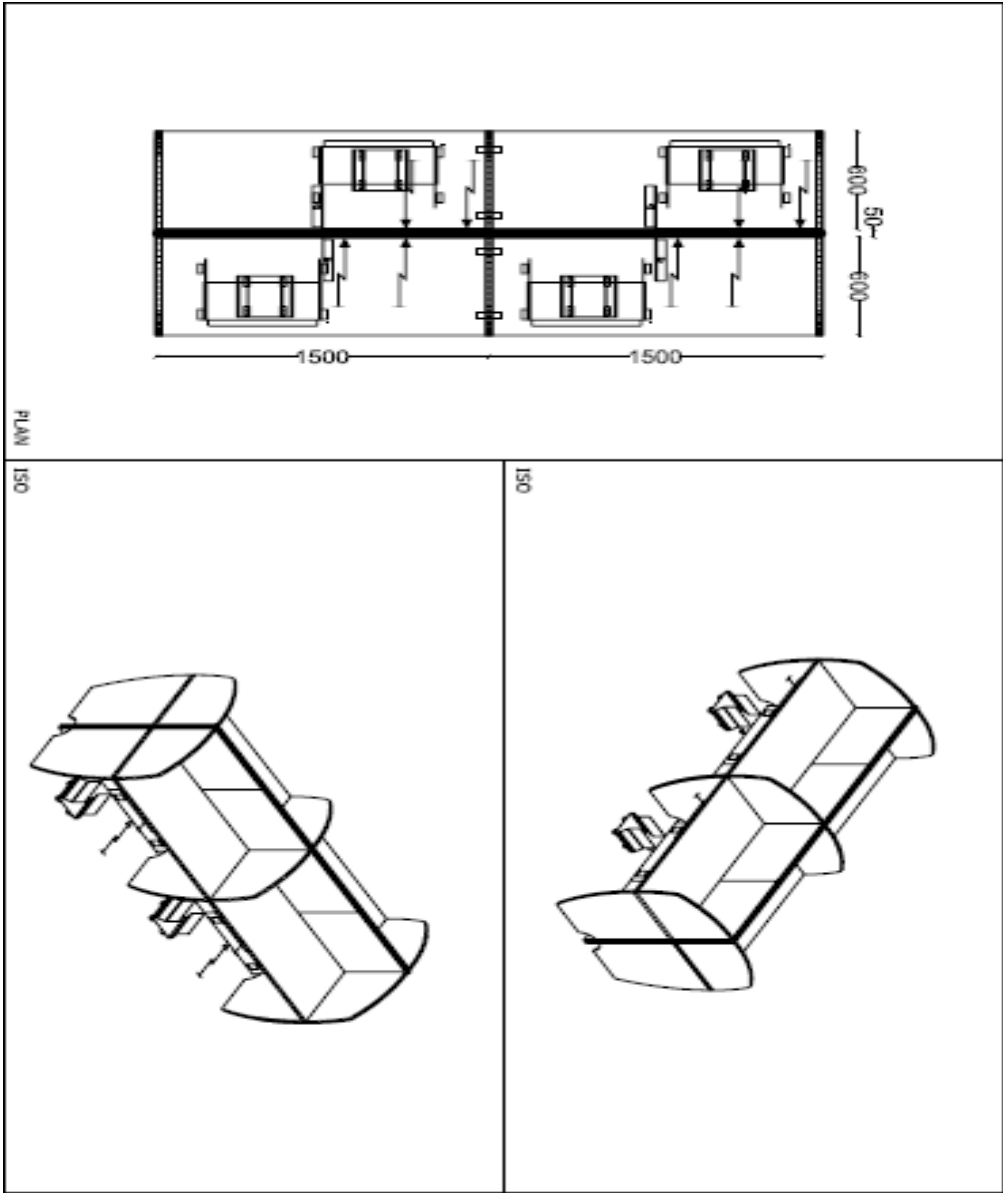

Annexure -5

Furniture for Computer Centre

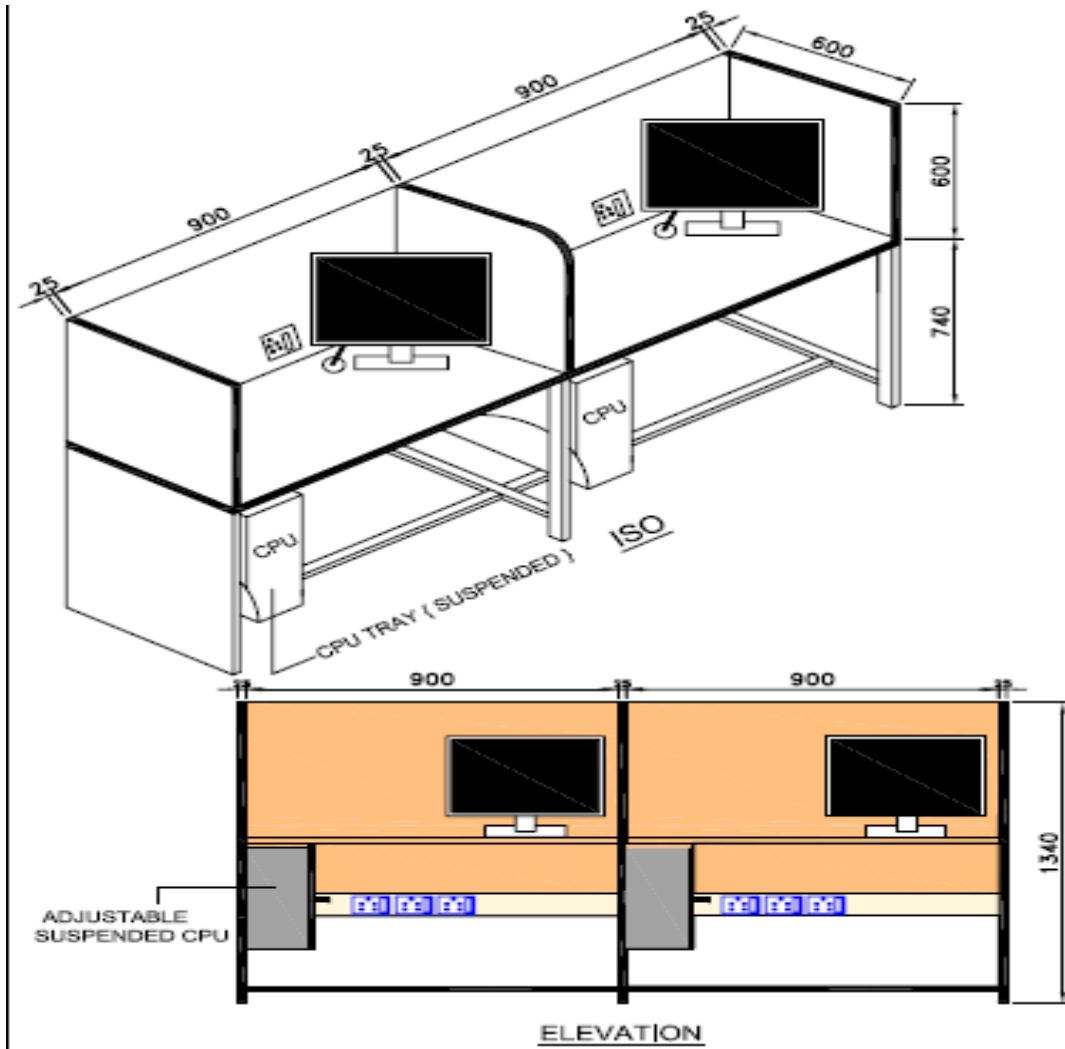

Annexure – 6

5. Chairs

Pinter Model 10810 / 10830

Dimension: W540xD560xH855-965 (nearly 1000-1500H for the model 10830)

Pneumatic Seat Height Adjustment

Back Height Adjustment. Without Armrests.



ILLUSTRATION 1: PINTER MODEL 10810



ILLUSTRATION 2: PINTER MODEL 10830

Annexure – 6

Bill of Material

S. No.	Laboratory Name	Sitting capacity	Workstation Specifications	Per Unit Price (INR)	Qty	Total Price (INR)
1	Heat and Fluid Dynamics	24				
3	Robotics and Instrumentation Lab	30				
4	Language Lab	36				
5	Microwaves and Electromagnetics	10				
6	Computer Centre	70				
6	Chairs	240	Pinter Model 10810			
		10	Pinter Model 10830			